



# Liquid Filled Transformer Applications

Music City Power Quality Conference

August 2, 2016



*Powering Business Worldwide*

# Discussion Topics

---

- Innovations in transformer design and protection to address arc flash concerns
- Reducing space and cost by integrating switchgear style overcurrent protection directly in the transformer
- Hardened liquid filled transformer designs for critical load applications
- Rightsizing your transformer kVA selections utilizing 75° C rise transformers
- Review of scope and impact of DOE 2016 efficiency standards
- Rethinking substation designs from traditional overhead to all pad-mount
- Modular integrated transportable substations
- Triplex core transformers can solve the toughest installation challenges

# 3-phase transformer product scope

## Pad-mounted and substation transformers

- kVA range
  - 45-12,000
  - ONAN / KNAN
  - ONAF / KNAF
- Primary voltage
  - 2400 to 46,000 volts
  - Up to 250 kV BIL
- Secondary voltage
  - 120 to 15,000 volts
  - 125 kV BIL



# Assessing arc flash risk

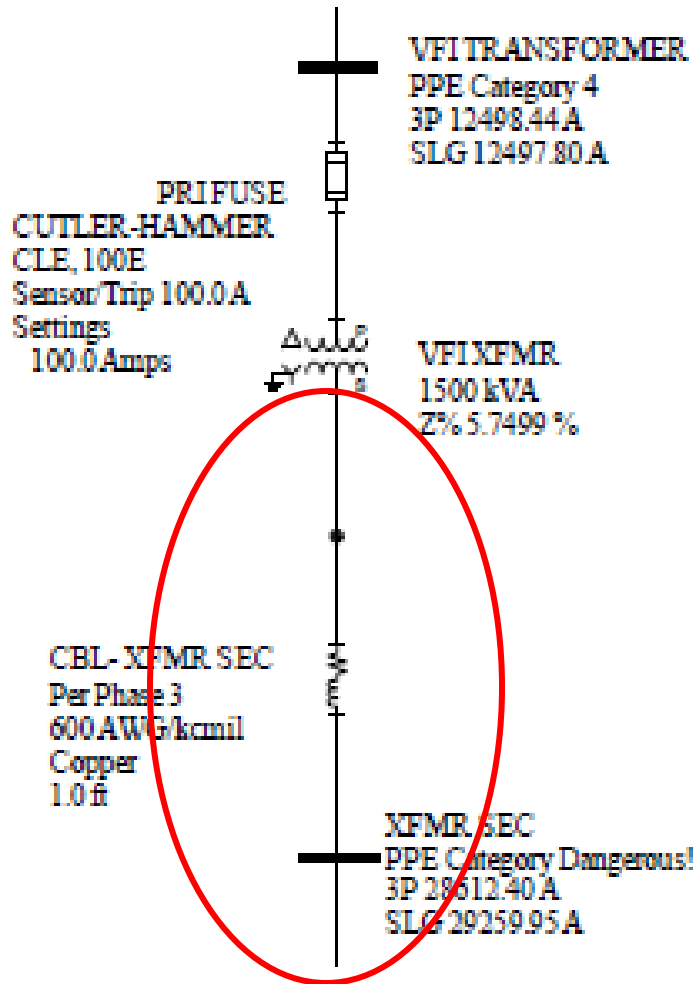

- Secondary side of substation transformers are typically high arc flash risk zones
- Trip times are long because arc faults have to reflect through the transformer
- Primary fuses react very slowly to secondary arcing and ground faults

# Assessing arc flash risk

- 1500 kVA Xfmr %Z = 5.75
- Bolted fault current = 28.84 kA
- Arcing fault current = 16.20 kA

Arcing current reflected through transformer would take **in excess of 6 seconds to clear primary fuse!**

Location	Device	Bolted Fault (kA)	Arcing fault (kA)	Arc Flash Boundry (in)	Incident Energy (cal/cm <sup>2</sup> )	PPE Level
Xfmr Sec	Pri Fuse	28.8	16.2	286	112	Dangerous!
Sec Swgr	Pri Fuse	28.8	16.2	285	111	Dangerous!

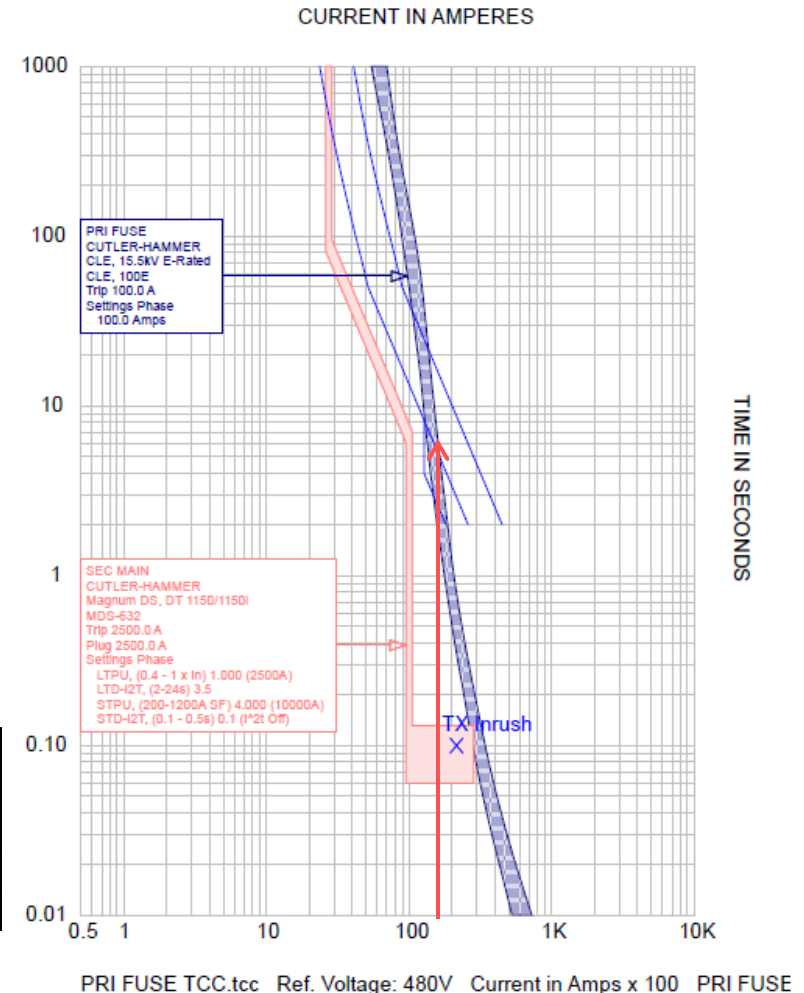

# Transformer with Primary Fuse Protection





# External gages, valves, nameplates



External control box



External nameplate

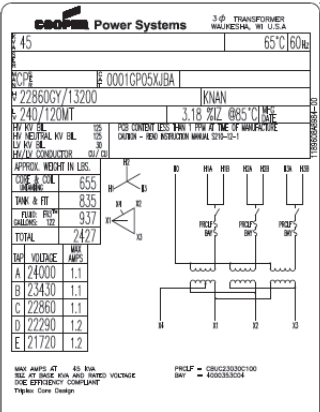

External gages



External sampling valve

# External visible break switches

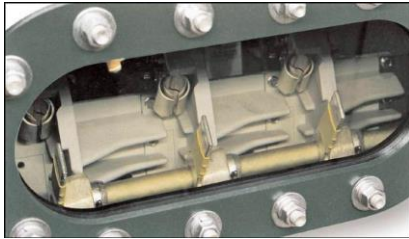

Open contacts



IR windows

- Transformer with external load break switch eliminates need to access the HV compartment
- Addition of visible break enhances ability to verify open contacts
- IR windows allows inspection of connections externally



# Solutions for existing transformers

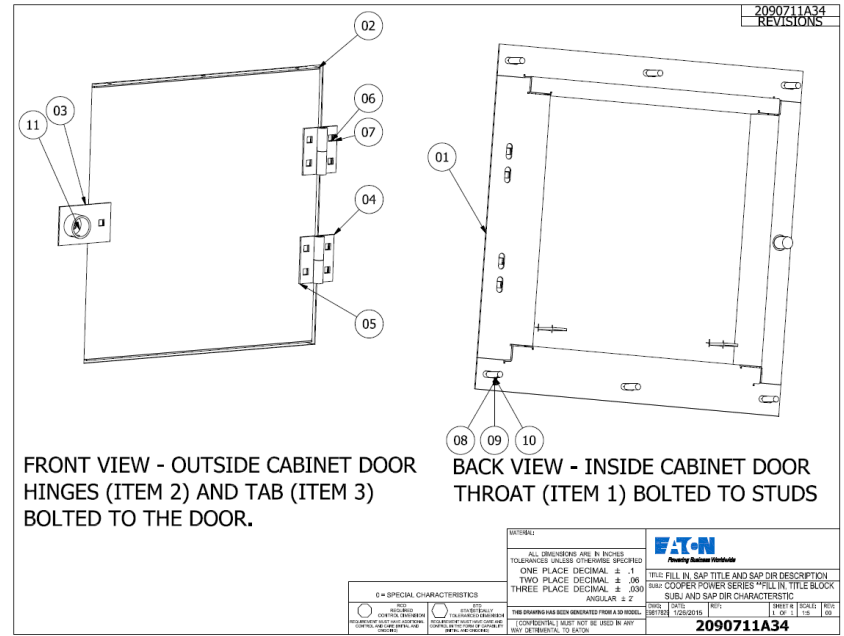
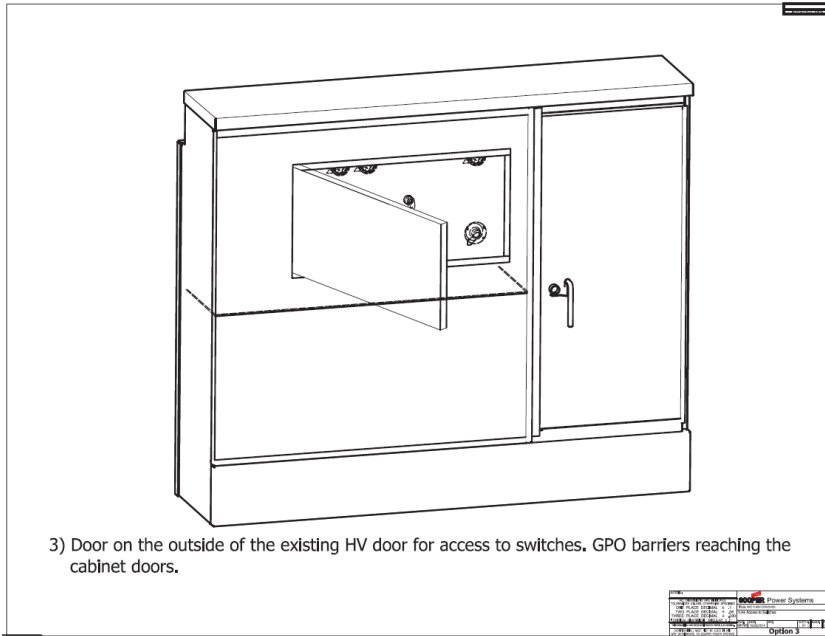

# Transformer with external switchgear

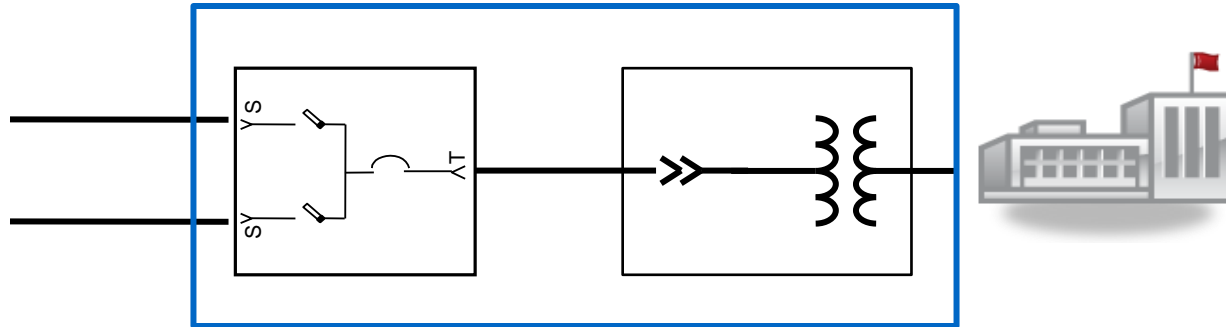

Desirable when ....

- Transformer FLA exceeds fuse ratings
- Three-phase protection desired
- Resettable protection desired
- More sophisticated protection schemes like differential protection or arc flash reduction desired
- Common in unit substation designs
- Eaton is in a unique position because we manufacture both liquid filled transformers and switchgear

# VFI transformer



- Vacuum fault interrupter installed integral to the transformer
- Switchgear-type overcurrent protection for large pad mounted or substation transformers
- Common on our larger kVA transformers



# VFI transformer

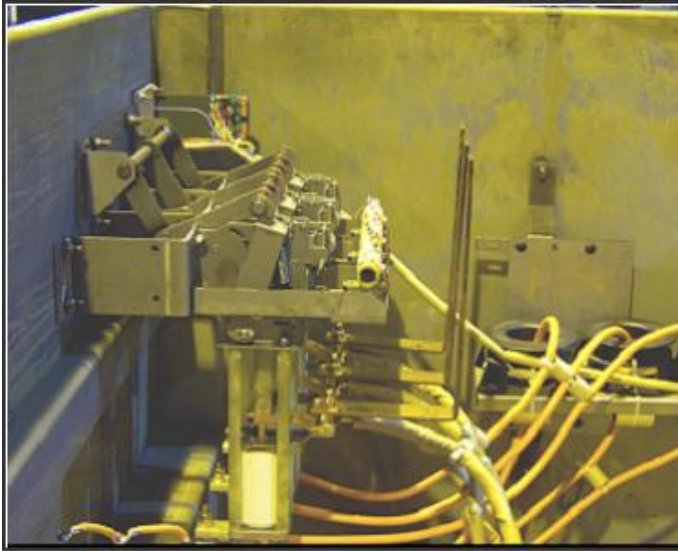

- 750-10,000 kVA
- Primary voltage thru 34.5 kV, 150 kV BIL
- 600 A continuous
- 16 kA RMS interrupting at 15 kV
- 12.5 kA RMS interrupting at 25 & 35 kV
- Current limiting fuses can be used at some ratings to reach 50 kA
- Relay options from simple 50/51 protection to microprocessor based differential protection

# Visible break

- Visible break switch in series with vacuum fault interrupter
- Available in 2 and 3 positions
  - Open/close
  - Open/close /ground

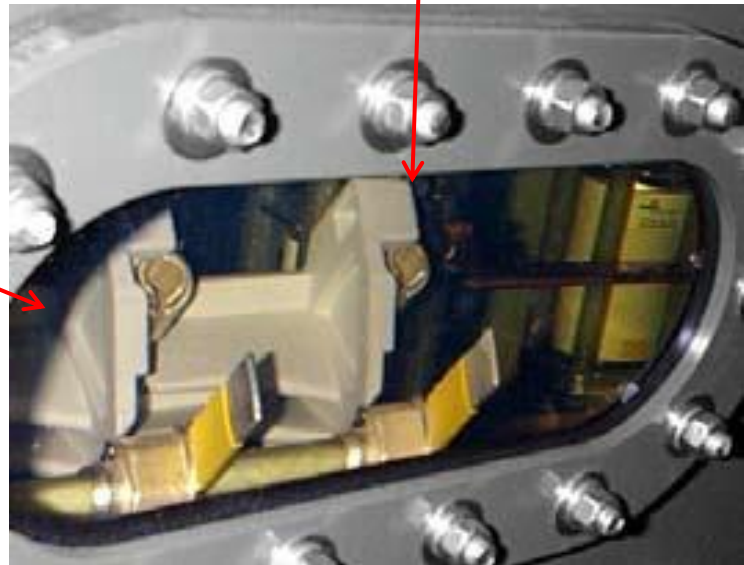
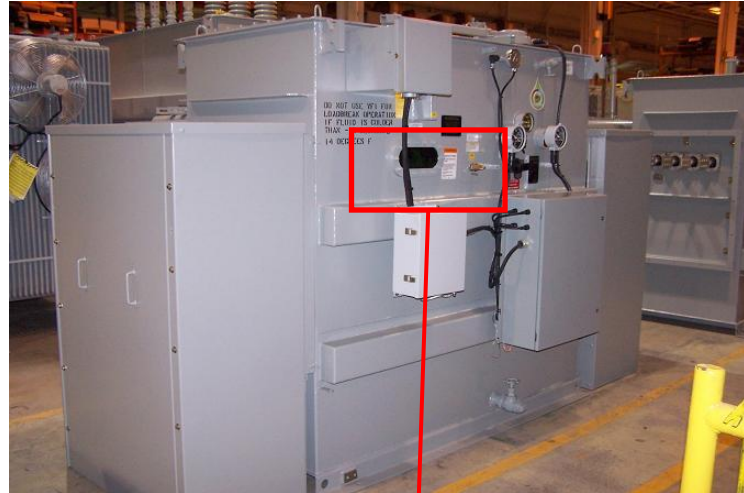
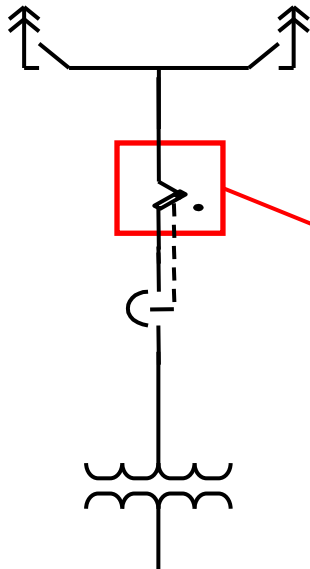



# Dry transformer line-up

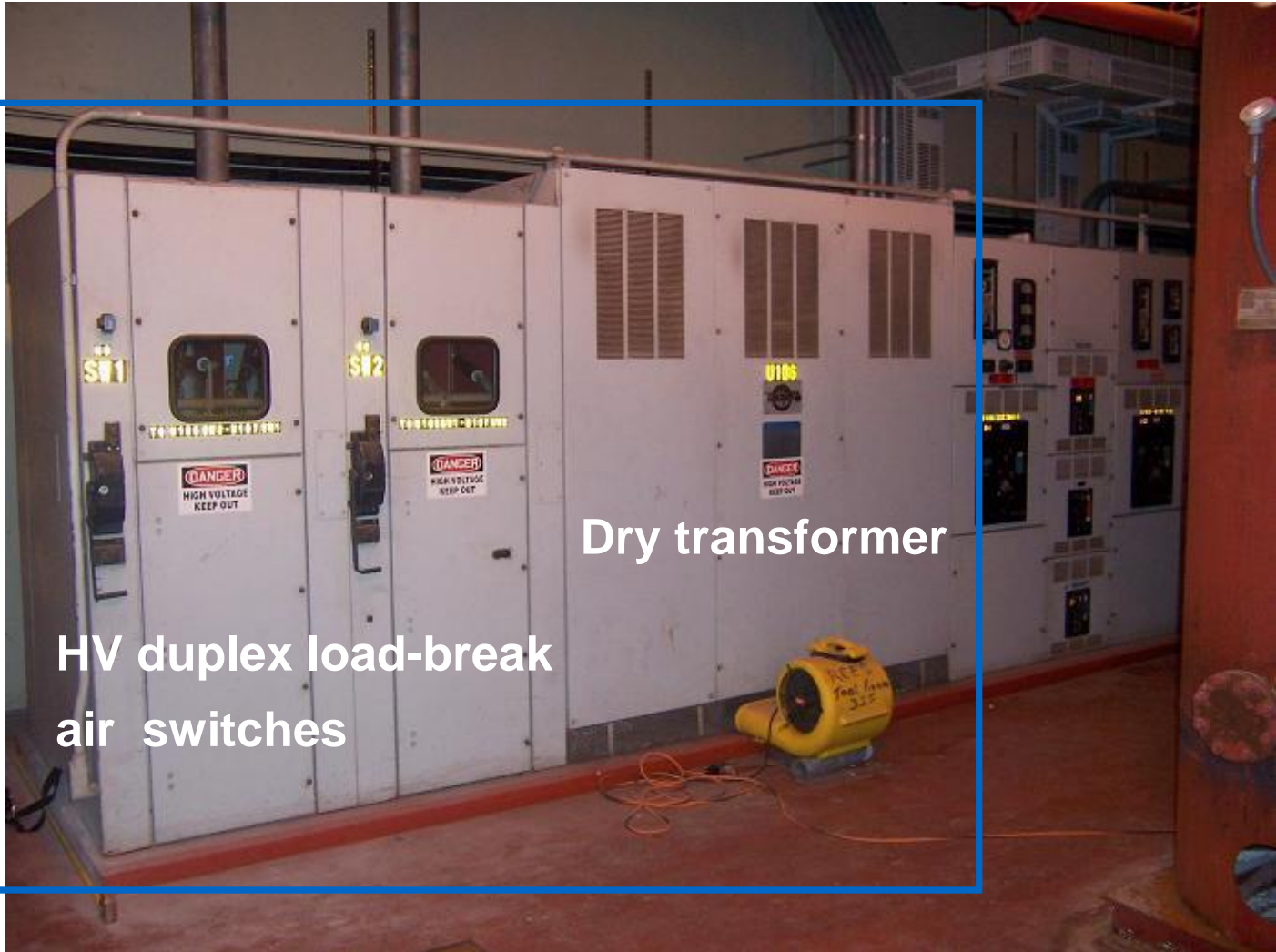

Dry transformer

HV duplex load-break  
air switches



# Liquid-filled VFI transformer

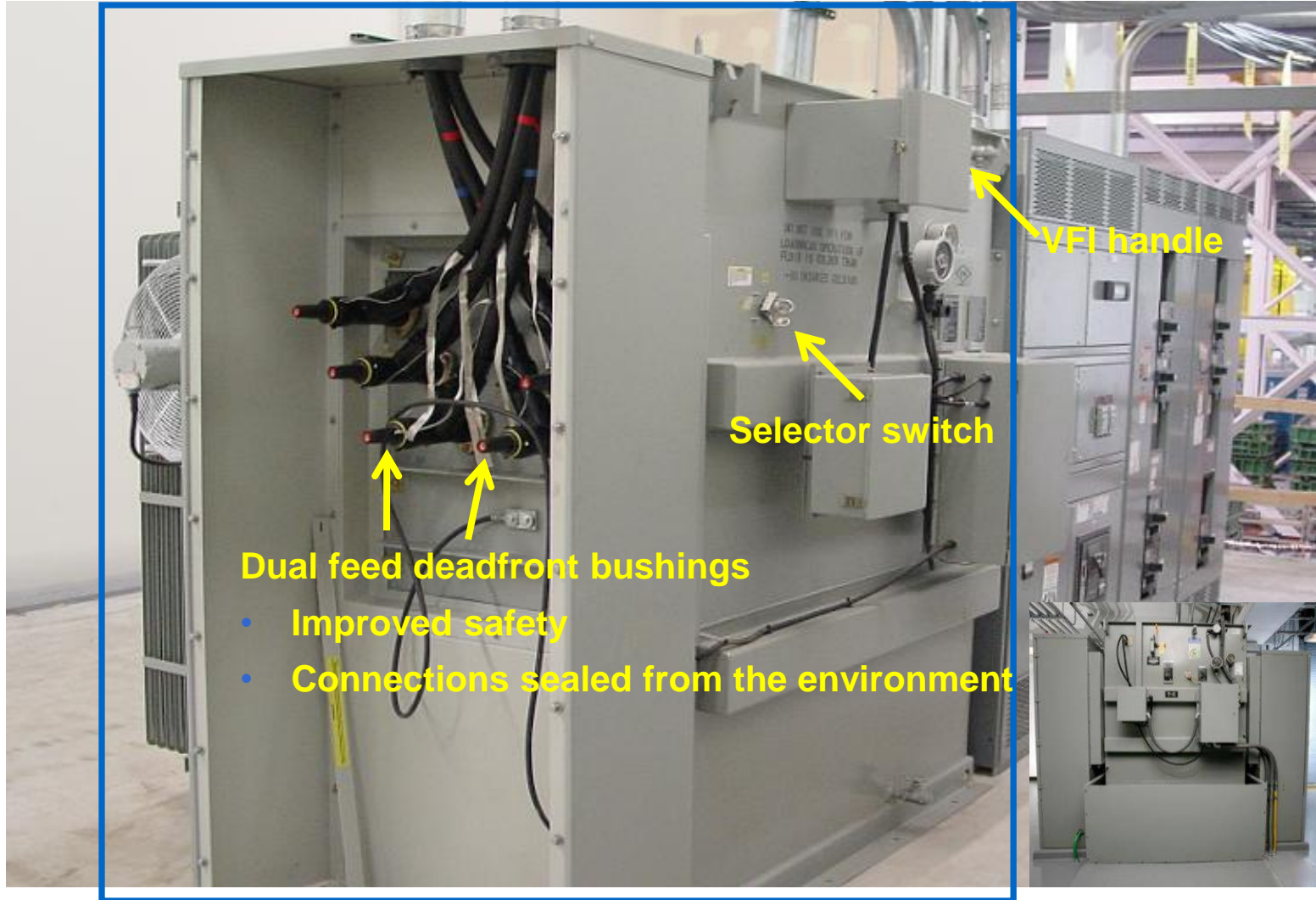

# Physical comparison

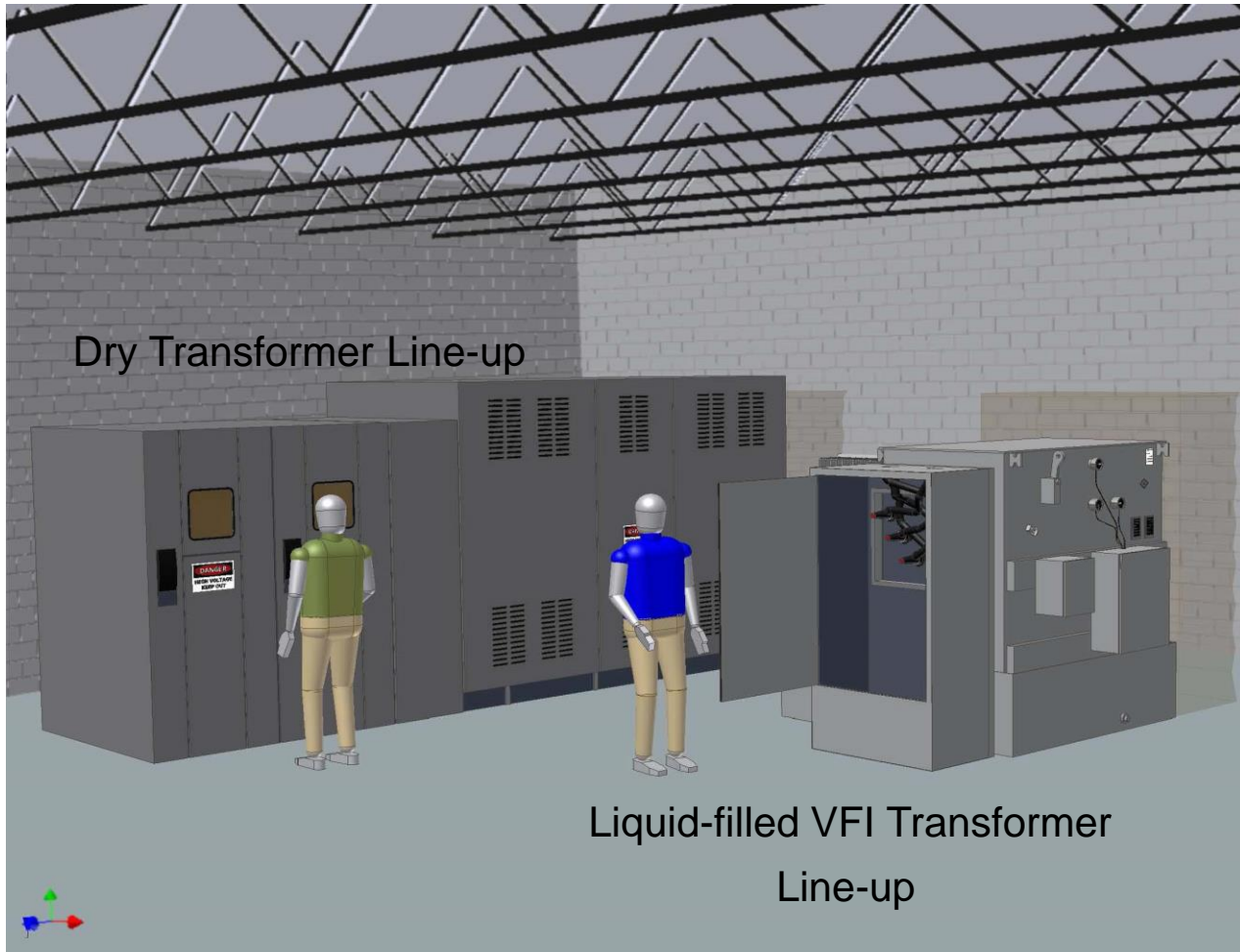

Each line-up performs the same function

# Arc Flash reduction with VFI transformer

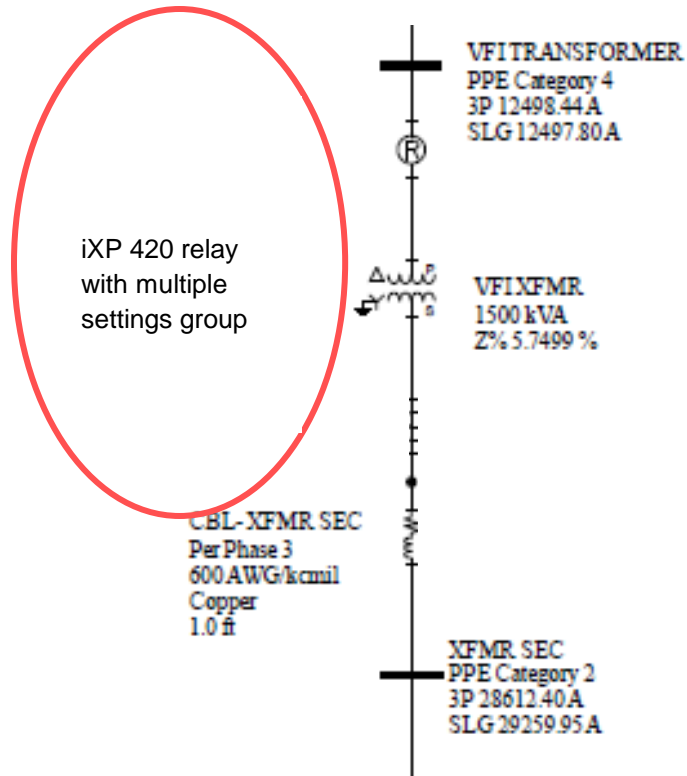

- Use VFI transformer with microprocessor control for primary protection
- Utilize 2 settings groups, standard and maintenance mode
- Apply maintenance mode to reduce fault timing and lower the incident energy of the arcing fault when LV cable compartment access is required

# Arc Flash reduction with VFI transformer

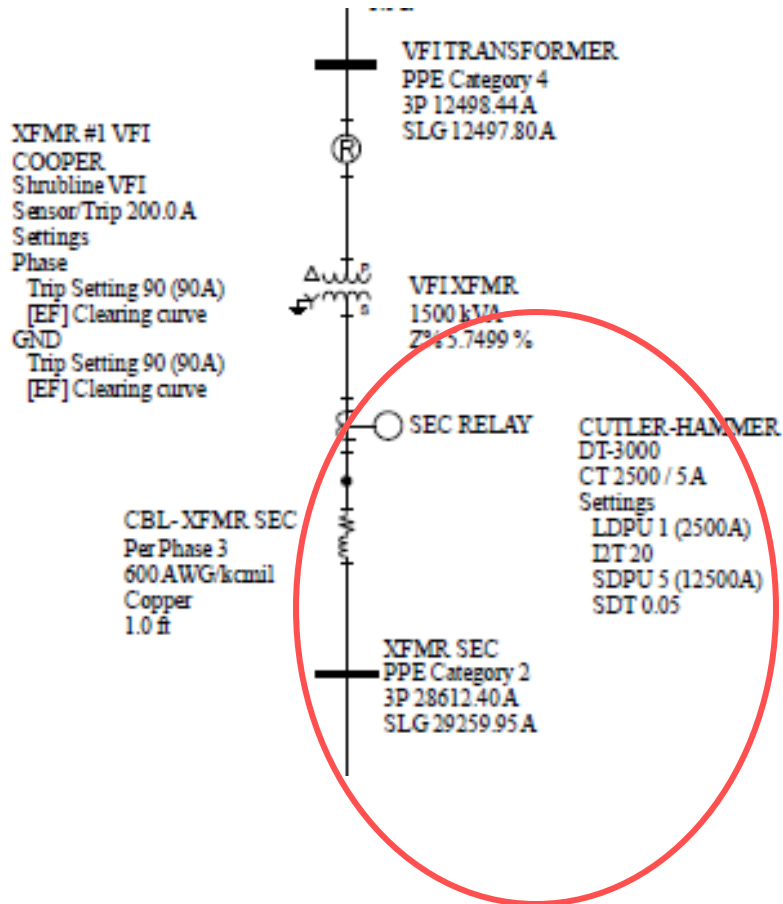

- Use VFI transformer with standard control and SCADA option
- Provide CT's on secondary bushings or spades
- Provide 50/51, 50G/51G overcurrent relay protection on secondary
- Use relay trip signal to remote trip primary VFI
- Apply as a permanent scheme to reduce fault timing to lower the incident energy of the arcing fault

# Secondary arcing fault: VFI options

- 1500 kVA Xfmr %Z = 5.75
- Bolted fault current = 28.84 kA
- Arcing fault current = 16.20 kA

**Total clearing time of only 0.100 sec (100 msec)!**

Completely adjustable protection to allow customization of arc flash reduction

Location	Device	Bolted Fault (kA)	Arcing Fault (kA)	Arc Flash Boundary (in)	Incident energy (cal/cm <sup>2</sup> )	PPE Level
Xfmr Sec	Sec Relay	28.8	16.2	46	5.6	Level 2
Sec Swgr	Sec Relay	28.8	16.2	46	5.6	Level 2

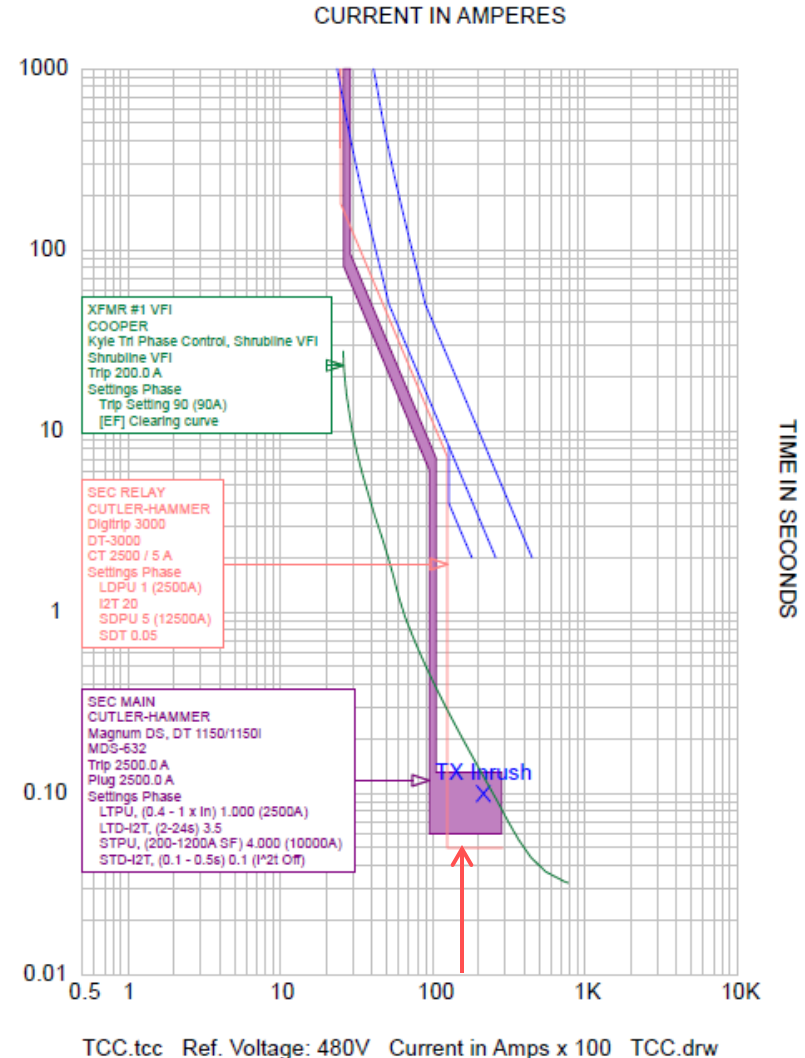

# Vacuum circuit breaker transients

- RC snubber circuits are used under certain conditions to protect dry type transformer from transient voltages caused by vacuum breaker switching
- To date, we have not supplied snubbers with our liquid filled hardened data center (HDC) transformers and we have no reports of VCB switching failures with over 2,500 MW installed capacity
- With 15 plus years of VFI transformers installations, we have not seen any incidents where switching the transformer with the VFI has led to failures

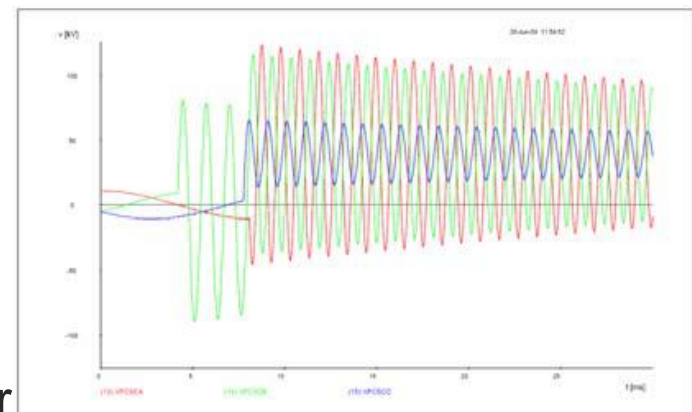



# Vacuum circuit breaker transients

- In order to quantify these field results, we conducted testing on our liquid filled HDC transformers to see how these transients affected our designs.
- Testing has confirmed that our liquid filled HDC designs do not need snubbers. A white paper detailing the study is available.



# What Causes Higher Switching Transient Voltages?

- Medium Voltage VCB characteristics
  - Higher chopping current = Higher switching transient voltage
  - Increased number of medium voltage VCB arc prestrikes/restrikes = Higher switching transient voltage
- Feeder cable/bus size and length
  - Smaller sized cable/bus and/or shorter cable/bus = Higher switching transient voltage
- Inductive load (Transformers, motors, etc.)
  - Light, highly inductive load = Higher switching transient voltage
- Transformer internal resonant frequencies
  - Switching transient frequency aligning with transformer resonant frequency = Significantly higher switching transient voltage

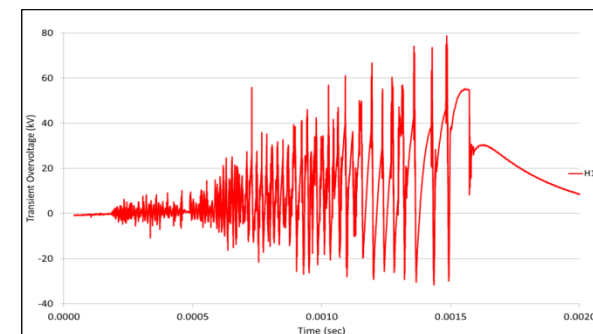
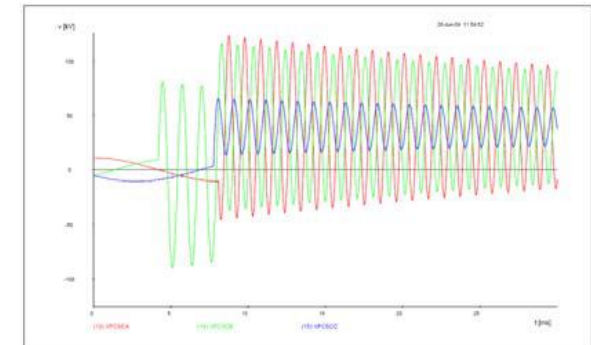
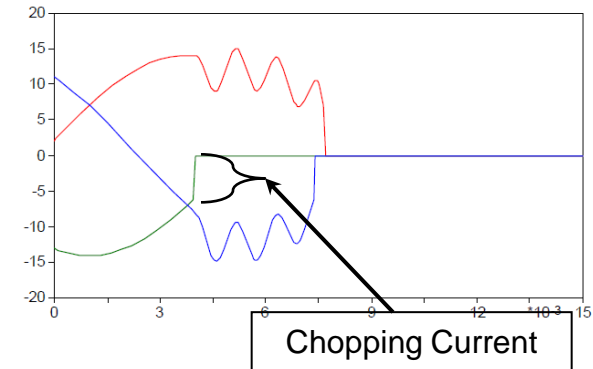

# Sweep frequency response analysis

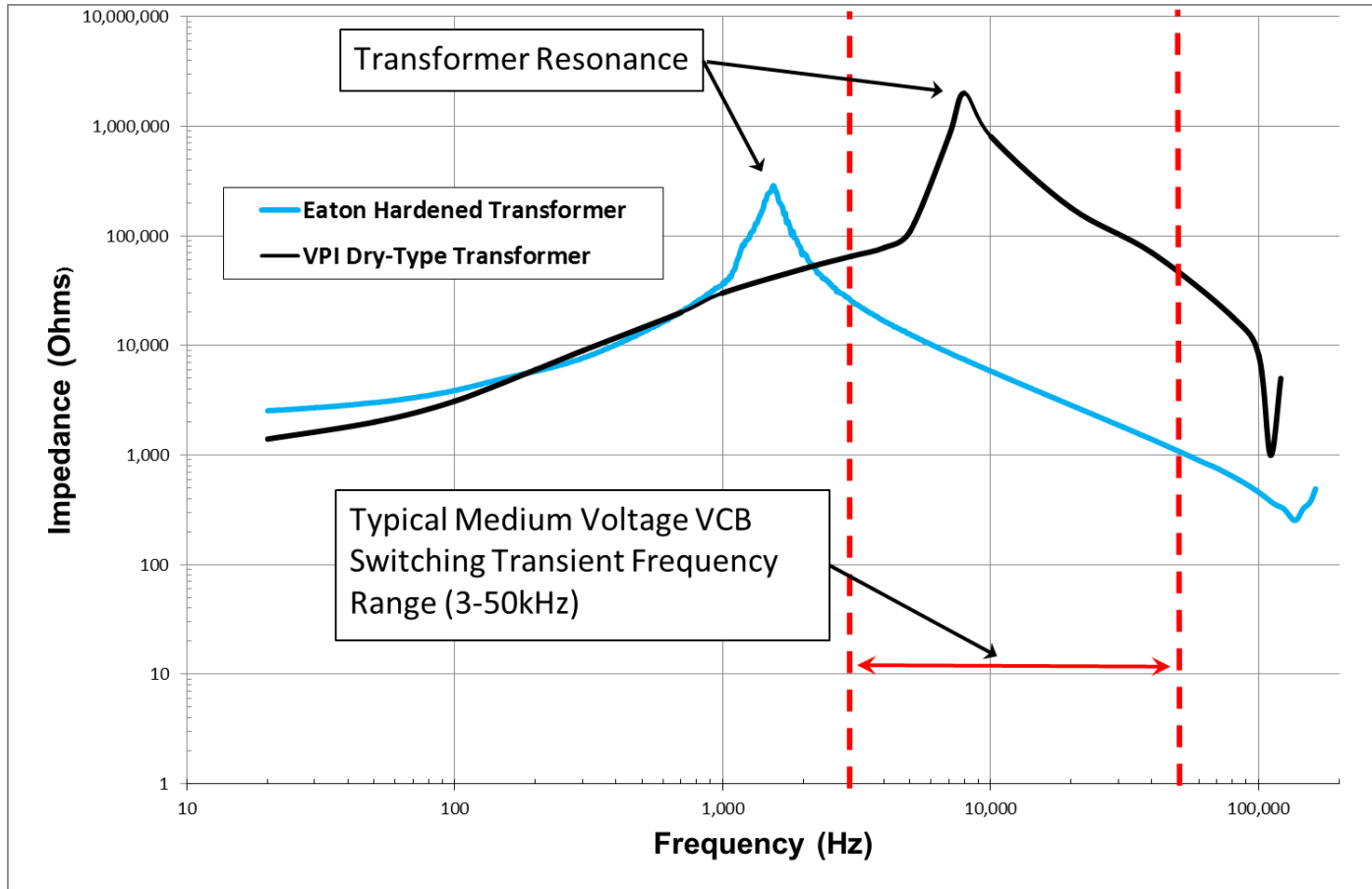

# HDC versus VPI

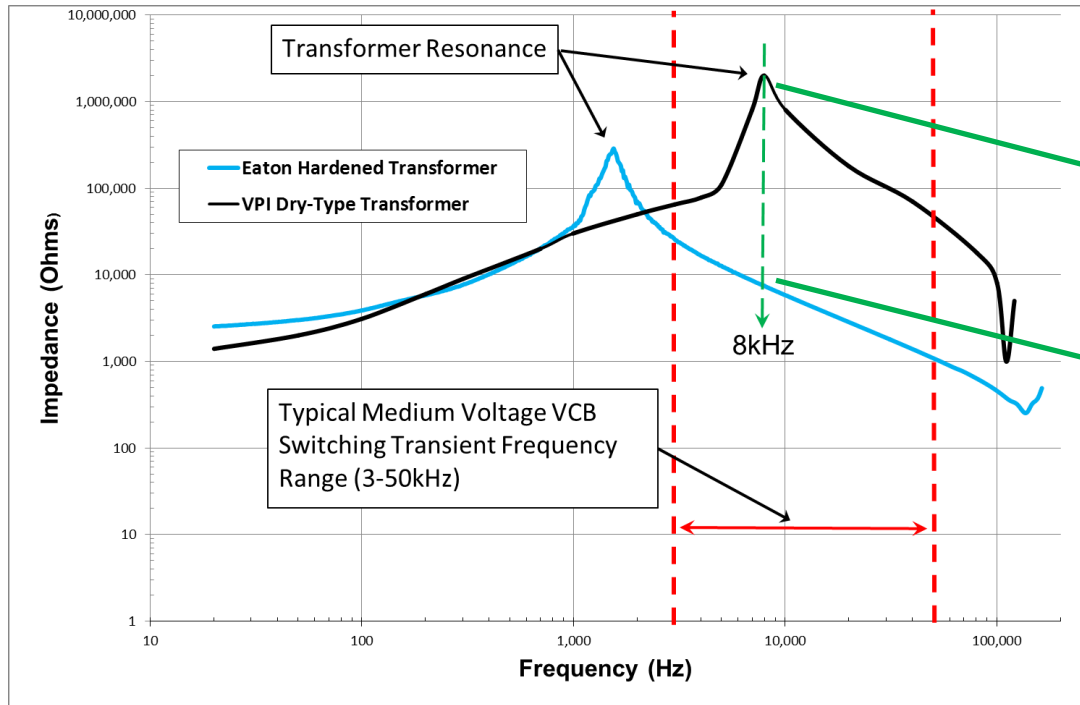

- 8kHz Switching Transient System Voltage Amplification Factor
- VPI Dry-Type Transformer = **1250 p.u. of Applied System Voltage**
- Eaton Hardened Transformer = **1.78 p.u. of Applied System Voltage**
- **Voltage seen by VPI Dry-Type transformer is 702 times greater**

# Testing

Switching transient testing was performed at the Eaton High Power Lab (HPL) in Franksville, WI

Specialized direct measurements taken at 13.8 kV

- Terminals and taps at 1/3 and 2/3 of winding

Switching was performed with a primary side medium voltage VCB, or VFI internal to transformer tank

Test circuit consisted of the source, medium voltage VCB, cable, hardened transformer, & load bank

The test sequence consisted of:

1. Close VCB or VFI to energize the transformer
2. Apply a highly inductive light load consisting of a load bank on the transformer secondary
3. After some time elapsed, the VCB or VFI was opened to de-energize the transformer
4. Repeated steps 1 thru 3 varying the primary switching device, cable size/length, X/R ratio of the light load, surge arrester, and snubber.

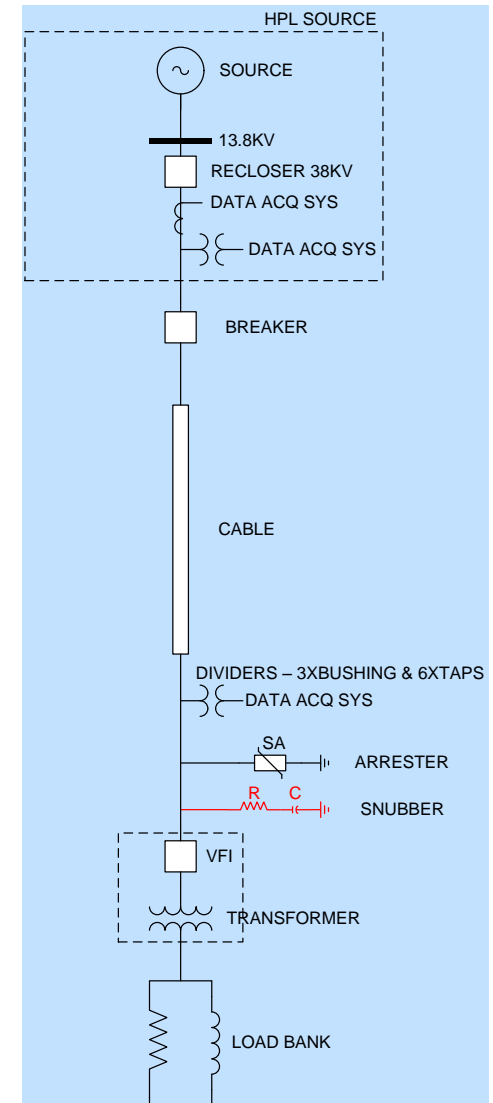

# Test summary of most significant events

trace	VCB or VFI	Snubber	Arrester	Cable	Length (m)	Full Winding Transient Overvoltage						Tap Transient Overvoltage			
						major peak		secondary peak		tertiary peak		1/3 tap		1/3 of winding	
						kV	kV/usec	kV	kV/usec	kV	kV/usec	kV	kV/usec	kV	kV/usec
10	VCB#1 <sup>1</sup>	No	18kV	250	30	-63	83.2	-60.1	91.5	-59.2	91	-39.2	2.8	-21.9	0.7
14	VCB#1	Yes	27kV	250	3	14.26	0.008	-14	0.008	10	0.008	8.05	0.008	7.61	0.008
40	VCB#1	No	27kV	#2	3	-81.9	183	-79.1	266	-72.7	298	-44.1	8.1	-25.6	0.4
57	VCB#2 <sup>2</sup>	No	27kV	250	30	59.7	0.4	-40.6	0.75	-21.7	0.37	45.2	0.4	27.7	0.23
78	VCB#2	No	27kV	#2	3	81.8	190	78.6	168	69.7	123.5	35.6	8.2	-25.1	1.4
93	VFI <sup>3</sup>	No	27kV	#2	3	N/A	N/A	N/A	N/A	N/A	N/A	-57.2	0.39	54.9	0.39
131	VCB#2	No	No	#2	3	71.95	302.5	-66.5	242	62	146	52.4	5.7	18.46	5.2
141	VCB#2	Yes	No	#2	3	30.16	0.024	N/A	N/A	N/A	N/A	22.56	0.017	15.4	0.013
146	VCB#2	No	No	#2	3	76.65	189.5	-76.45	65.3	37.25	200	-42.9	9.5	-25.38	0.5
148	VCB#2	No	No	#2	3	-77.9	184.5	-72.7	106.8	-67.9	235.5	-57.33	25.54	23.835	5.58
156	VCB#2	No	No	#2	3	78.8	86.5	73.3	115.25	55.8	143.7	56.8	5.7	30	0.74

**Notes:**

1. VCB#1 bolt-in 15kV, 1200A, 25kAIC and 3-5A chop.
2. VCB#2 1985 vintage 15kV, 1200A, 18kAIC and 19-21A chop.
3. VFI 35kV, 600A, 12.5kAIC and 3-5A chop

- The peak phase voltage on the H1, H2 or H3 terminal resulting from voltage escalation ranged from 30 kV to 82 kV
- The corresponding peak voltages at the 1/3 and 2/3 taps ranged from 15 kV to 55 kV.



# Validation

---

- A total of 157 VCB and VFI Close/Open operations were performed on the Eaton Hardened Transformer over a 1 week period
- Diagnostic testing was conducted on the Eaton Hardened Transformer before and after the switching transient testing was performed
  - Insulation Power Factor
  - Dissolved Gas Analysis (DGA)
  - Transformer Turns Ratio (TTR)
  - Insulation Resistance
  - Sweep Frequency Response Analysis (SFRA)
- All diagnostic testing was successful in that there was no change in readings before and after the switching transient tests, indicating there was no damage to the transformer insulation system

# Conclusions

- Eaton's fully tested hardened 1500KVA, 13.8/.48kV, 125kV BIL, Envirotemp™ FR3™ fluid-filled transformer was capable of withstanding the harsh medium voltage VCB switching transient conditions imposed on it in Eaton's High Power Lab, with no need for a snubber
- Eaton's Cooper Power series transformers' natural frequencies are attractive at avoiding resonance produced in conjunction with medium voltage VCB or Eaton VFI switching devices
- Additional SFRA studies done on 1000-10,000kVA Eaton Cooper Power series transformers showed the withstand capability of the tested 1500KVA Hardened Transformer design can be extrapolated to all other Eaton Cooper Power series Liquid Filled Hardened Transformer designs.
- Eaton recommends the use of snubber circuits **unless** the manufacturer can provide **full testing documentation** as proof that the transformer is able to withstand switching transient voltages and avoid harmful resonant frequencies

# Increased reliability

- 200 kV BIL rated systems now available in a deadfront as opposed to only livefront systems
- Higher ratings for 35 kV and 600 or 900 A systems
- Heavier insulation system can withstand spikes in power
- Potential for longer life of the transformer
- Reduced footprint compares to live front

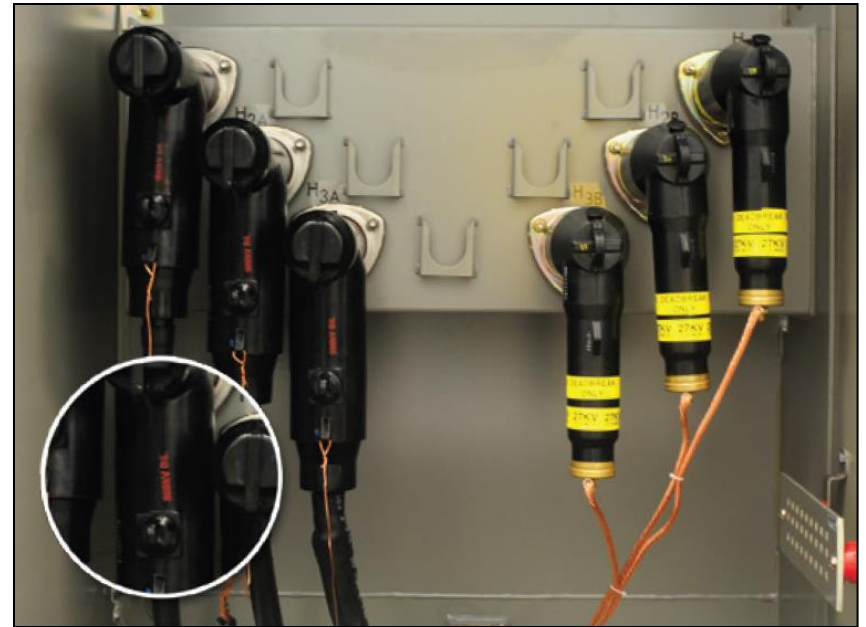

# Fuse types

- Expulsion Fuses
  - Low magnitude faults
    - Secondary faults with transformer impedance in circuit
  - Overloads
  - Bay-O-Net mounted
  - Cartridge mounted



# Fuse types

- Current-limiting Fuses
  - High magnitude faults
    - Faults without transformer impedance in circuit
    - Normally associated with an internally shorted (failing) transformer
  - If available fault current exceeds expulsion fuse rating, should use current-limiting fuse as back-up



# Expulsion & back-up CL fusing

Fusing – expulsion (Bay-O-Net mounted) & current-limiting

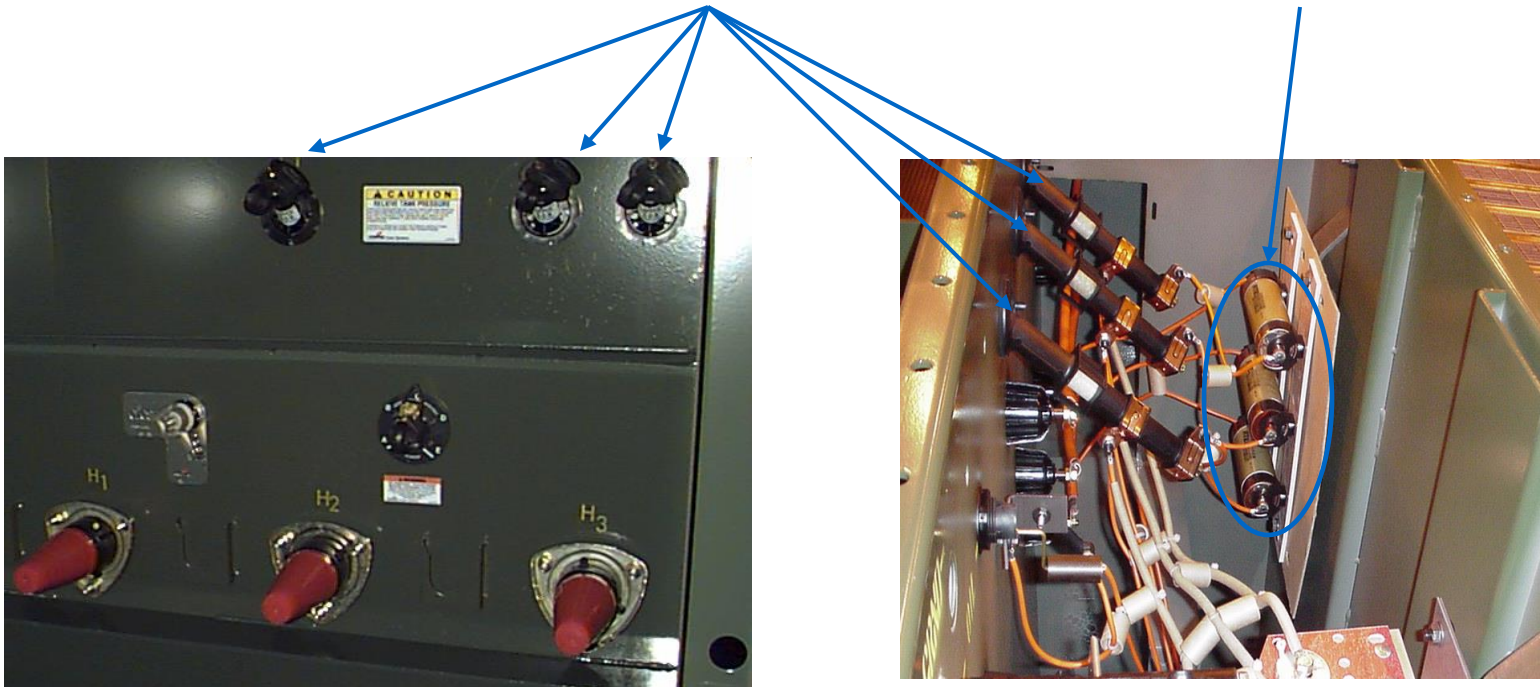



# Protection options

- Internal cartridge mounted expulsion fuse in series with partial range back-up current-limiting fuse
  - For higher ratings than Bay-O-Net mounting is rated

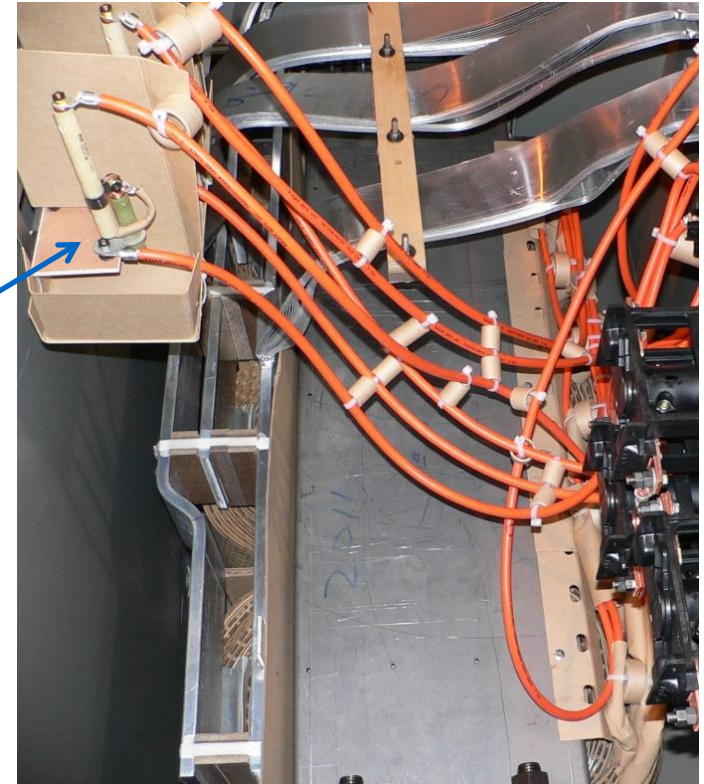

# New 38 kV bayonet fusing ratings

- Any Primary Voltage that is between 23,000 V and 38,000 V that is Delta or Y connected
  - 34,500 V Delta – 150 to 3200 kVA
  - 34,500 V Ungrounded Wye – 150 to 3200 kVA
  - 24,940 V Delta – 150 to 2300 kVA
  - 26,400 V & 27,600 V Delta – 150 to 2400 kVA



# History of Innovation

- “Guide for Loading Oil-Immersed Power Transformers with 65 °C Average Winding Rise”, TR98-1964, NEMA, 1964
  - “Guide for Loading Oil-Immersed Distribution and Power Transformers”, C57.32-1948, 1948
- New IEEE Std C57.154™-2012 standard published October 30, 2012

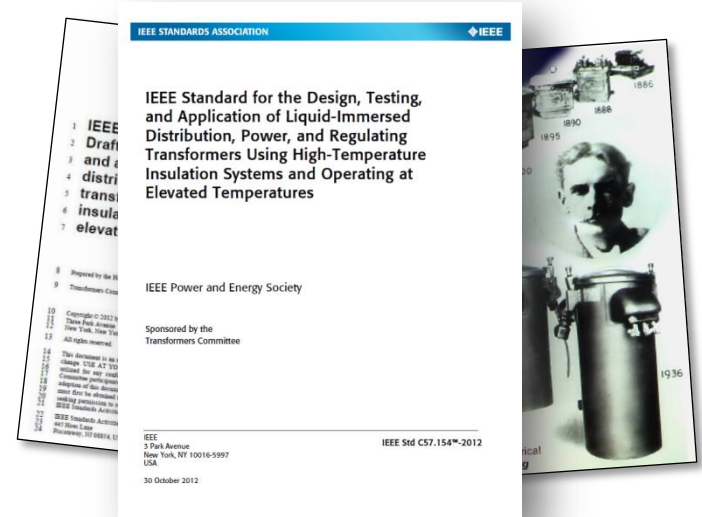

(1890-present)

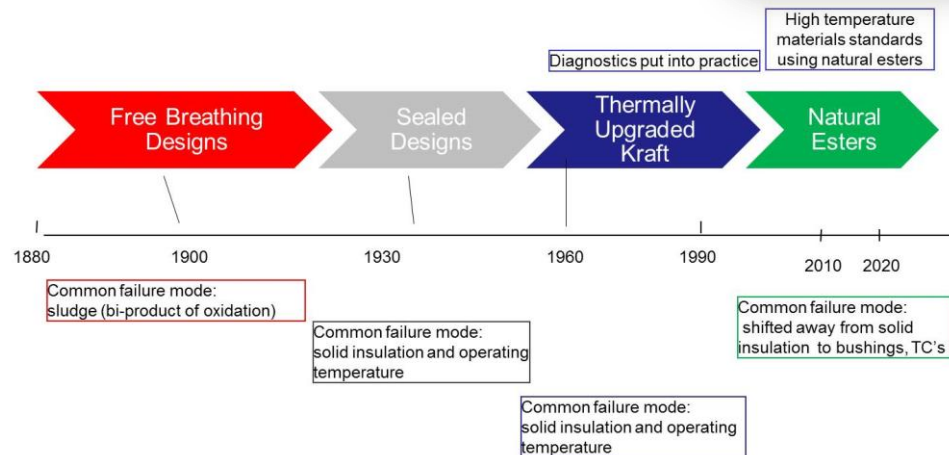

# FR3 natural ester based fluid

- Benefits
  - Fire safety characteristics
    - Classified per the NEC as less flammable fluid with fire point > 300°C.
  - Environmental characteristics
    - Renewable resource based on soy beans
    - EPA rated ultimate biodegradability
  - Enhanced performance characteristics
    - Enhanced thermal performance
    - Significant life extension of paper insulation

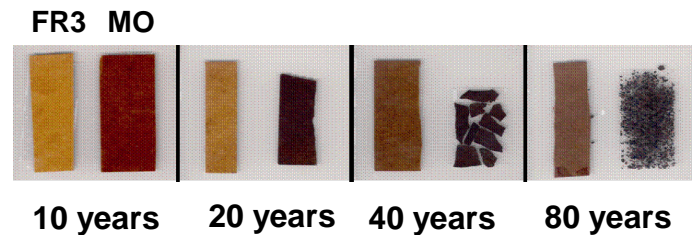

# Extended Insulation Life

	Standard MO	PEAK™ TRANSFORMER	PEAK™ TRANSFORMER
AWR(°C)	65	65/75	75
Design kVA	15	15	15
output kVA	15	15	15
Life	20yrs	160yrs	80yrs
Load%	100%	100%	100%
Hot Spot Temp	110	110	120

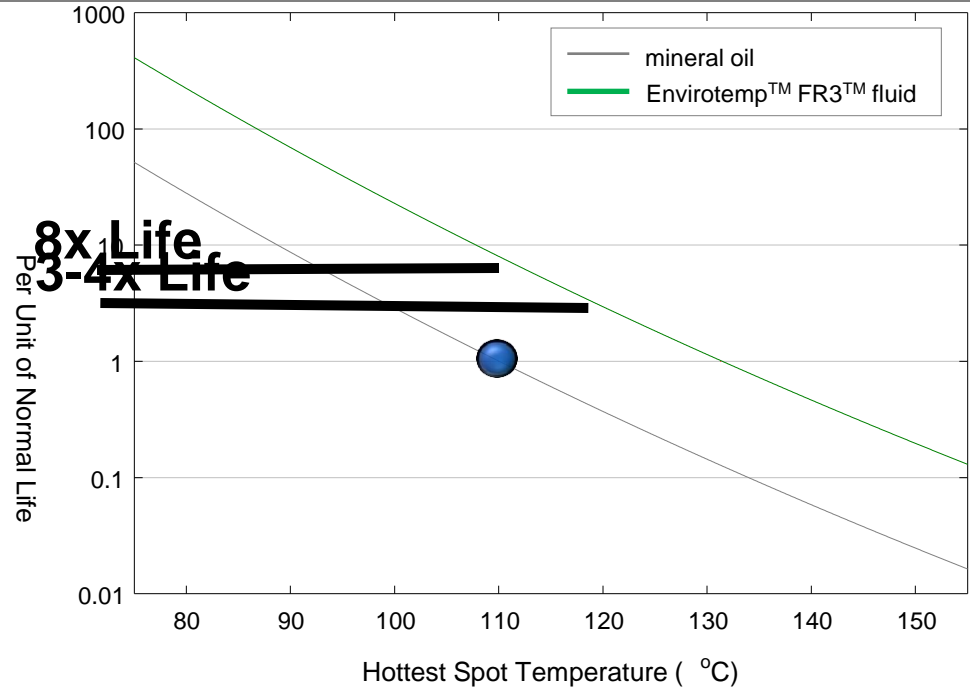

- IEEE C57.91 Loading Guide puts the Standard Life of a 65 AWR transformer
  - 20.55 years (one unit of life)
  - Typical Mineral Oil
- PEAK™ Transformers At 110°C Hottest Spot Temperature (65°C AWR) Represent Approximately 8x Longer Insulation System Life than 65 Rise Mineral Oil Filled Units

# Three core/coil optimizations

1. PEAK™ 65/75 °C average winding rise (AWR)
  - In lieu of traditional 55/65°C rise
  - 12% additional capacity
2. PEAK™ 55/75°C average winding rise (AWR)
  - 22% additional capacity
3. PEAK™ 75°C average winding rise
  - Typically uses less material and fewer gallons of dielectric fluid
  - More precisely size transformers based on periods of peak demand, without accelerated reduction of insulation life
  - UL Listed, UL classified
  - FM approved





# kVA ratings

55°C Rise KNAN (Base)	65°C Rise KNAN (Base x 1.12)	75°C Rise KNAN (Base x 1.22)		55°C Rise KNAF (Base x fan*)	65°C Rise KNAF (Base x 1.12 x fan*)	75°C Rise KNAF (Base x 1.22 x fan*)
500	560	610		575	644	702
750	840	916		863	966	1053
1000	1120	1221		1150	1288	1404
1500	1680	1831		1725	1932	2106
2000	2240	2442		2300	2576	2808
2500	2800	3052		3125	3500	3815
3750	4200	4578		4688	5250	5722
5000	5600	6104		6250	7000	7630
7500	8400	9156		9375	10500	11445
10000	11200	12208		12500	14000	15260
12000 <sup>a</sup>	13440 <sup>a</sup>	14640 <sup>a</sup>		15960 <sup>a</sup>	17875 <sup>a</sup>	19471 <sup>a</sup>

\* For less than 2500 kVA, fans increase kVA by 15%

\* For 2500 kVA-10000 kVA fans increase kVA by 25%

\* For 12000 kVA, fans increase kVA by 33%

\*\* All units available with 33% fan cooling upon request

a – specialty design, available on case by case basis

# Transformer losses

- Transformer losses consist of core losses and winding losses
- Core (no-load) losses always present 100% when transformer is energized
- Winding losses present only when load is on the transformer. Losses vary with square of the % of full load
  - Example:
    - A transformer has winding (load) losses of 10,000 watts when fully loaded
    - Transformer losses at 50% loading will be:
      - $50\%^2 = 25\% \times 10,000 \text{ watts} = 2500 \text{ watts}$



# TOC evaluation

$$\text{TOC} = \text{Purchase Price} + \text{Present Value of Energy Losses}$$

## Application Specifics

Base Rating		kVA
Nominal System Voltage, rms	13.2	kV
Cost of Energy	\$ 0.07	\$/kWh
Interest Rate (per annum)	4%	
Pay-Back Period for Analysis	7	yrs
Average Inflation Rate	2.00%	

# Rightsizing example #3

Choose unit subs, 13.2 kV - 480Y/277 V, for a double ended sub

Calculated load per NEC = 2000 kVA on each half. Total 4000 kVA

Common selection would be the next standard size up. Select 5000 kVA 65°C rise for each

Rightsize the transformer utilizing the 55/75°C KNAF(x 1.33) designs with fans. Select 2500/3052/4057 kVA



	65°C Rise	55°C Rise	75°C Rise
3750	3750	3750	6085
5000	5000	5000	8113
7500	7500	7500	12170
10000	10000	10000	16226
12000	12000	12000	19471

# Space requirements

- Cutting the base kVA rating in half with the 55/75° C KNAF results in a smaller lighter transformer
- Significant reductions over the dry type except depth of cooling fins.
- Reductions versus the 5000 kVA liquid are tempered by the 55/75° C base cooling.

kVA	5000	5000	2500/3325/4057	2500	2500
Type	dry	liquid	liquid	vs	vs
Temp rise	150	65 KNAN	55/75 KNAF	5000 dry	5000 liquid
Height	120	99	75	-38%	-24%
Width	138	75	71	-49%	-5%
Depth	72	123	88	22%	-28%
Weight	25,000	14500	13500	-46%	-7%

# TOC summary

- The calculated load is 2000 kVA X 50% = 1000 kVA actual
  - 1000/5000 = 20%
  - 1000/2500 = 40%.
- Large reduction in price and TOC for the 55/75° C KNAF
- The TOC calculations would change if loading required fan cooling however this mode of operation rarely exists.

kVA	5000	5000	2500/3325/4057	2500	2500
Type	dry	liquid	liquid	vs	vs
Temp rise	150	65 KNAN	55/75 KNAF	5000 dry	5000 liquid
Core loss	11400	7539	2501		
Wdg loss @ 100%	48000	40039	16160		
LF @ 1000 kVA	20%	20%	40%		
Total losses @ LF	13320	9141	5087		
PV of losses	\$ 51,904	\$ 35,620	\$ 19,822	-62%	-44%
Xfmr Price	\$ 113,516	\$ 83,620	\$ 68,314	-40%	-18%
TOC	\$ 165,420	\$ 119,240	\$ 88,136	-47%	-26%



# Summary

---

Rightsizing transformers with optimized 75° C transformers:

- Reduces the overall footprint required
- Reduces the initial cost of the transformer
- Reduces the TOC of the transformer
- Reduces the available arc energy
- Reduction in available fault current makes selective coordination easier

# DOE 2016

---

- Ruling published: April 18, 2013
- Effective compliance date: January 01, 2016
  - Raised efficiency levels above levels published in initial standard
  - Aside from higher efficiency levels, revised standard similar to initial standard
    - Scope, definitions, enforcement, compliance methodologies, loading (50% load)
  - Energy conservation groups lobbied for higher standards
    - DOE noted potential for significant disruption in steel supply



# Transformers in scope for DOE 2016

---

- Manufactured for sale in United States
- Low-voltage dry-type transformers
- Medium-voltage dry-type transformers
- Liquid-filled medium-voltage distribution transformers
- Input voltage up to 34.5 kV
- Output voltage up to 600 V

# Efficiency change

- Efficiency is the ratio of useful power output to total power input
- Difficult to grasp magnitude when discussing changes in % efficiency
- An increase in efficiency is conversely a *reduction* in the inefficiency of the transformer:

$$Efficiency = 100 * \left( \frac{LF * kVA * 1000}{(LF * kVA * 1000) + NL + (LL * LF^2)} \right)$$

$$Inefficiency = 100 - efficiency$$

- NL = No load loss
- LL = Load loss
- LF = Load factor

# Inefficiency reduction example

- Transformer type = liquid-filled
  - Phase quantity = 3
  - kVA = 1500
  - DOE 2010 efficiency = 99.42%
  - DOE 2016 efficiency = 99.48%
  - DOE load factor = 50%
- 
- *Inefficiency of DOE 2010 transformer* =  $100\% - 99.42\% = 0.58\%$
  - *Inefficiency of DOE 2016 transformer* =  $100\% - 99.48\% = 0.52\%$
  - *Inefficiency reduction* (%) =  $\left(\frac{.58-.52}{.58}\right) * 100 = 10.34\%$

# 3-Phase liquid-filled: DOE 2010 vs. DOE 2016

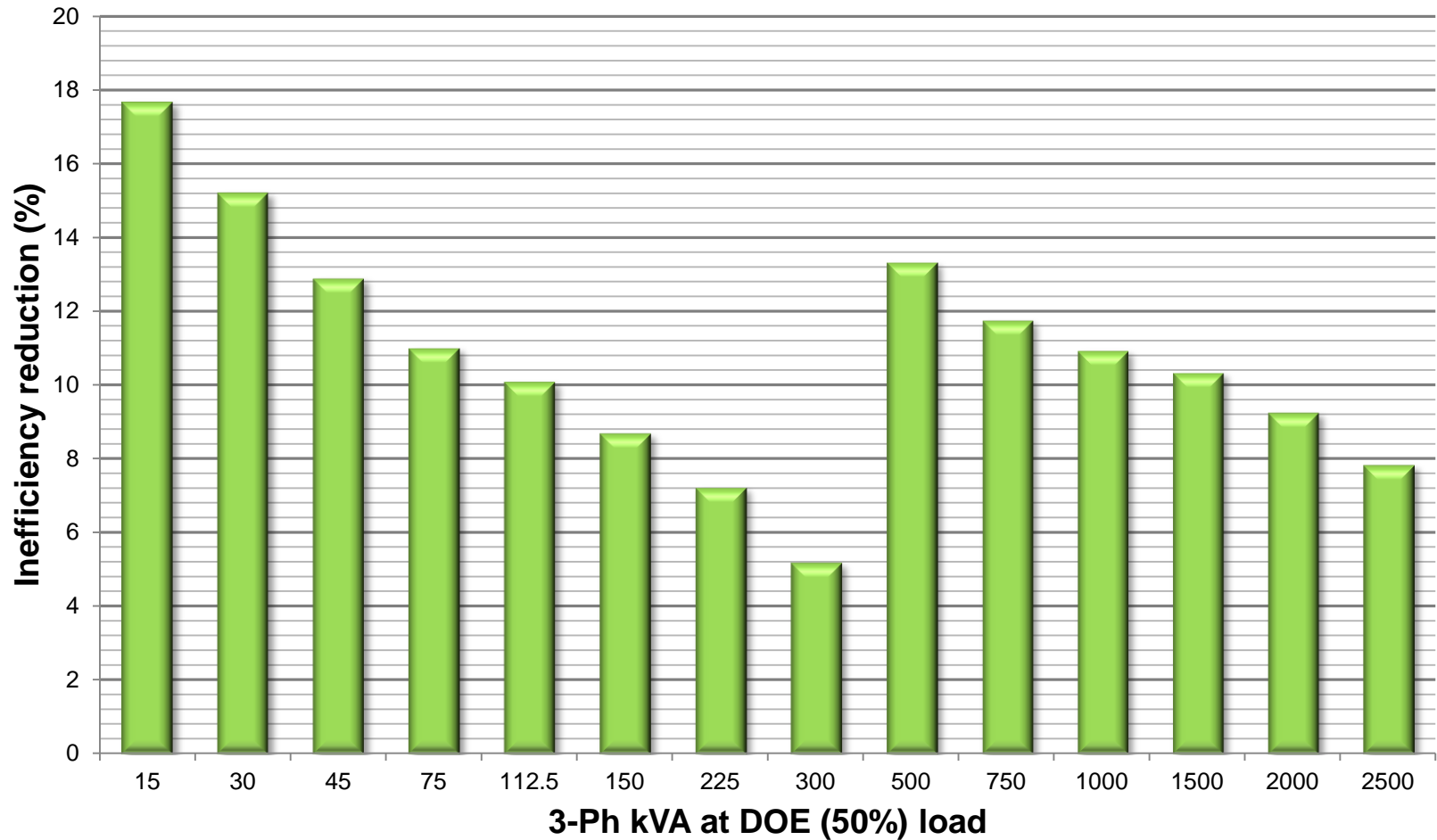



# Weight change example: 3-phase pad-mounted

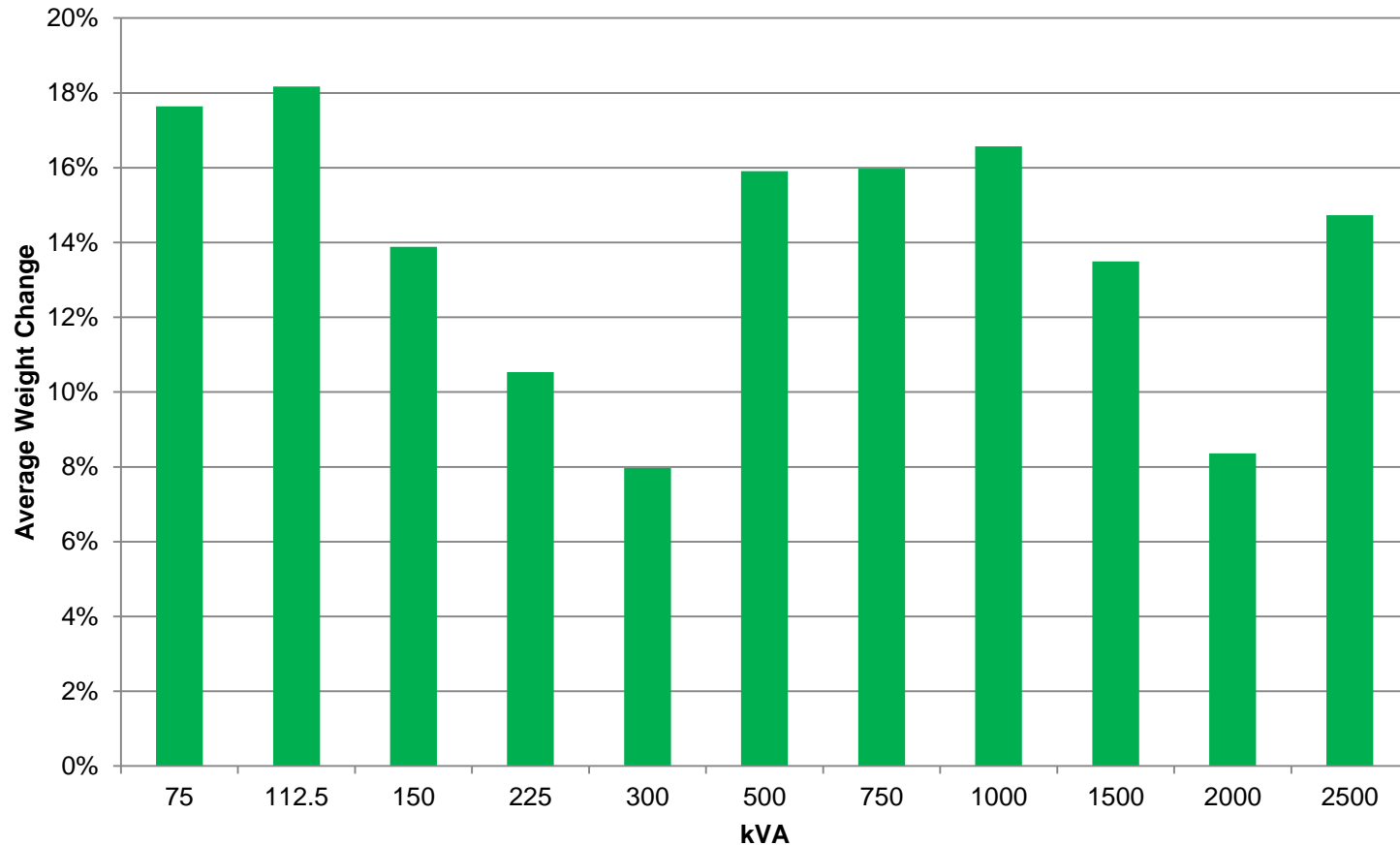

# Optimizing core material

---

- DOE 2016 efficiencies can be achieved using Grain Oriented Electrical Steel (GOES) for most designs
- Amorphous may be leveraged to obtain the most cost effective DOE 2016 design
  - Primarily 3-phase transformers with high current secondaries
    - Example: 750 kVA with 208Y/120 secondary voltage
  - Evidence suggests GOES provides lowest cost DOE 2016 1-phase designs
- Eaton is well suited to determine ideal design to meet inputs provided

# Efficiency example – 500 kVA 3-phase

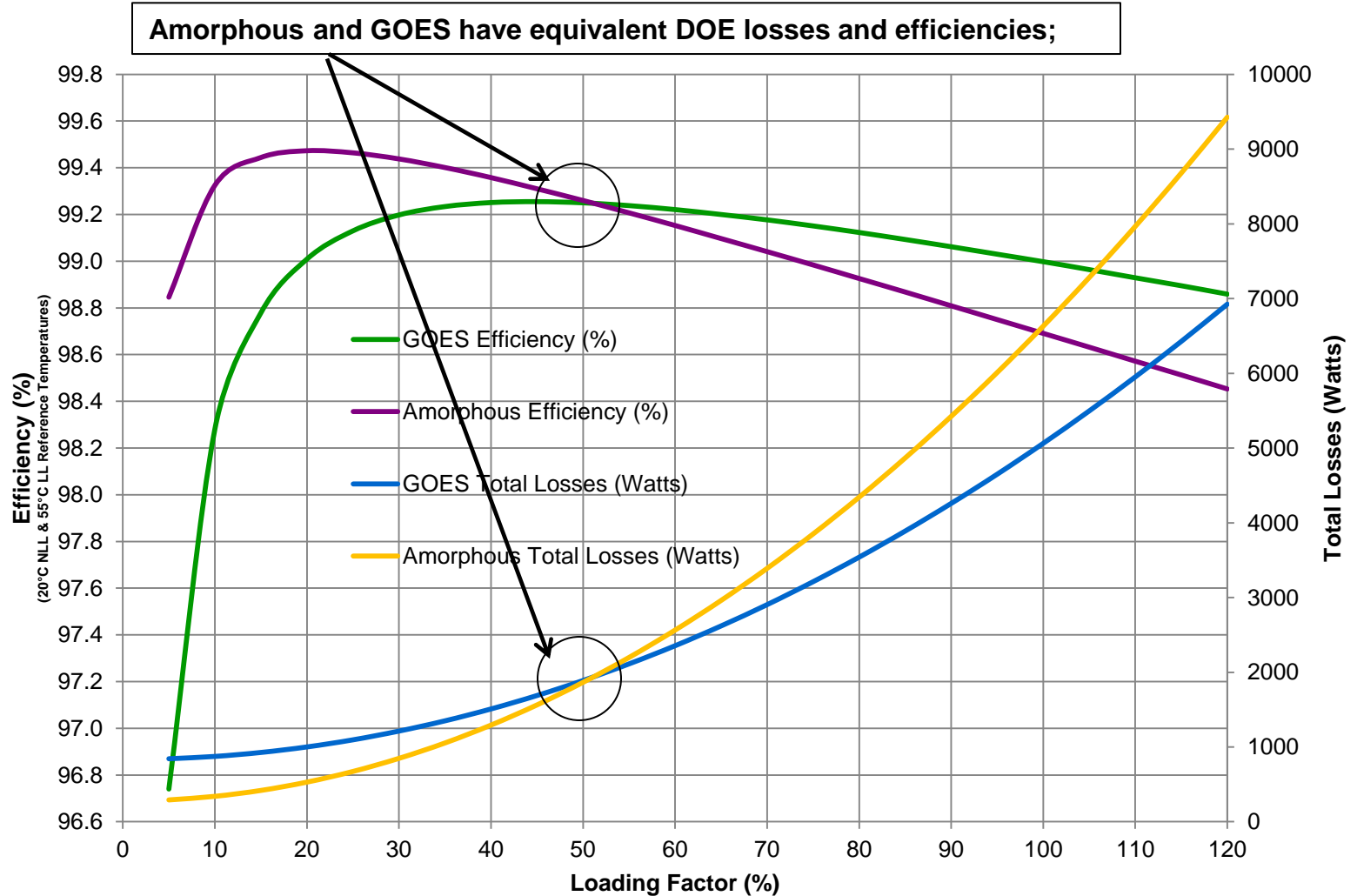

# Liquid filled vs. dry type efficiency comparison

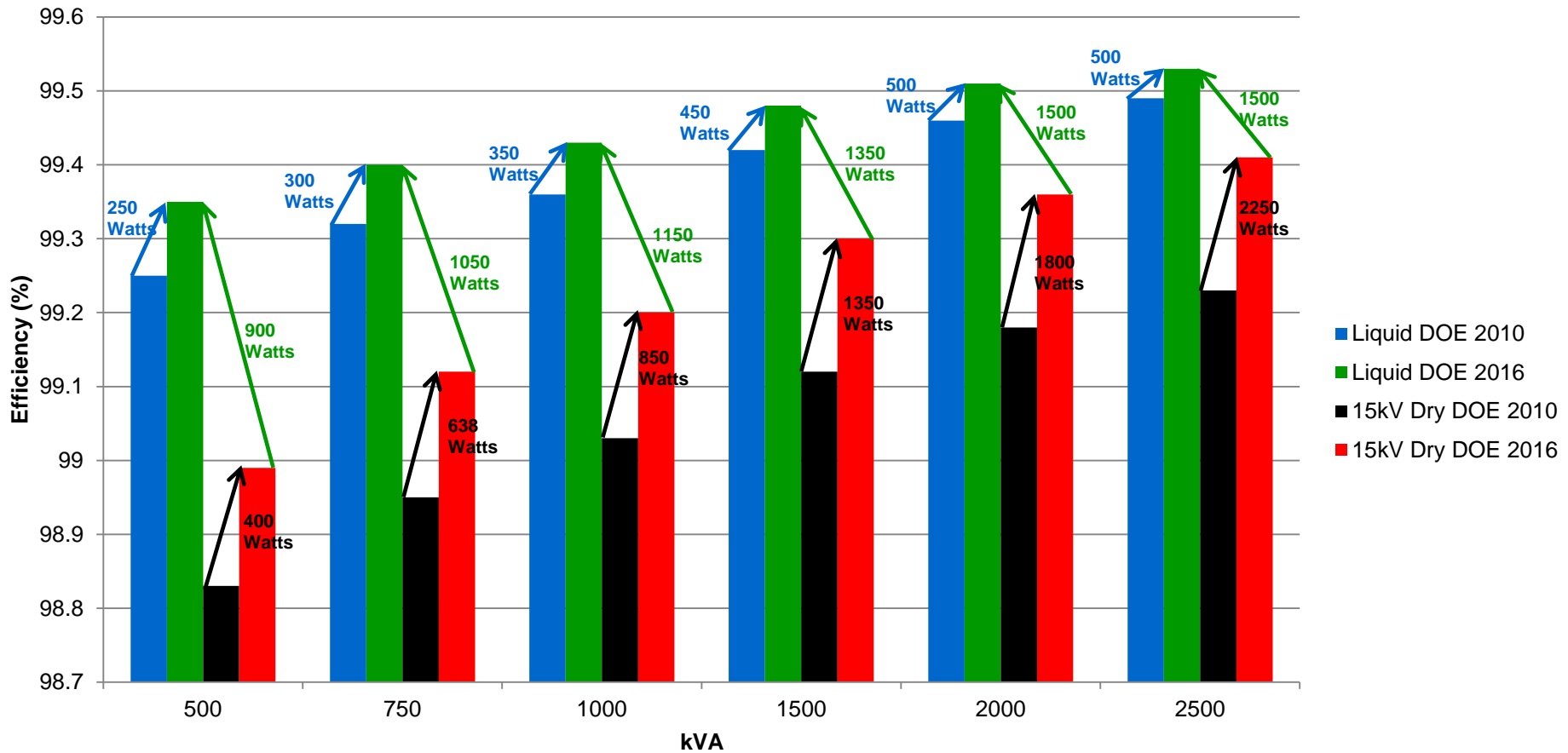

# Operational costs

## 20 Year Cost of Losses

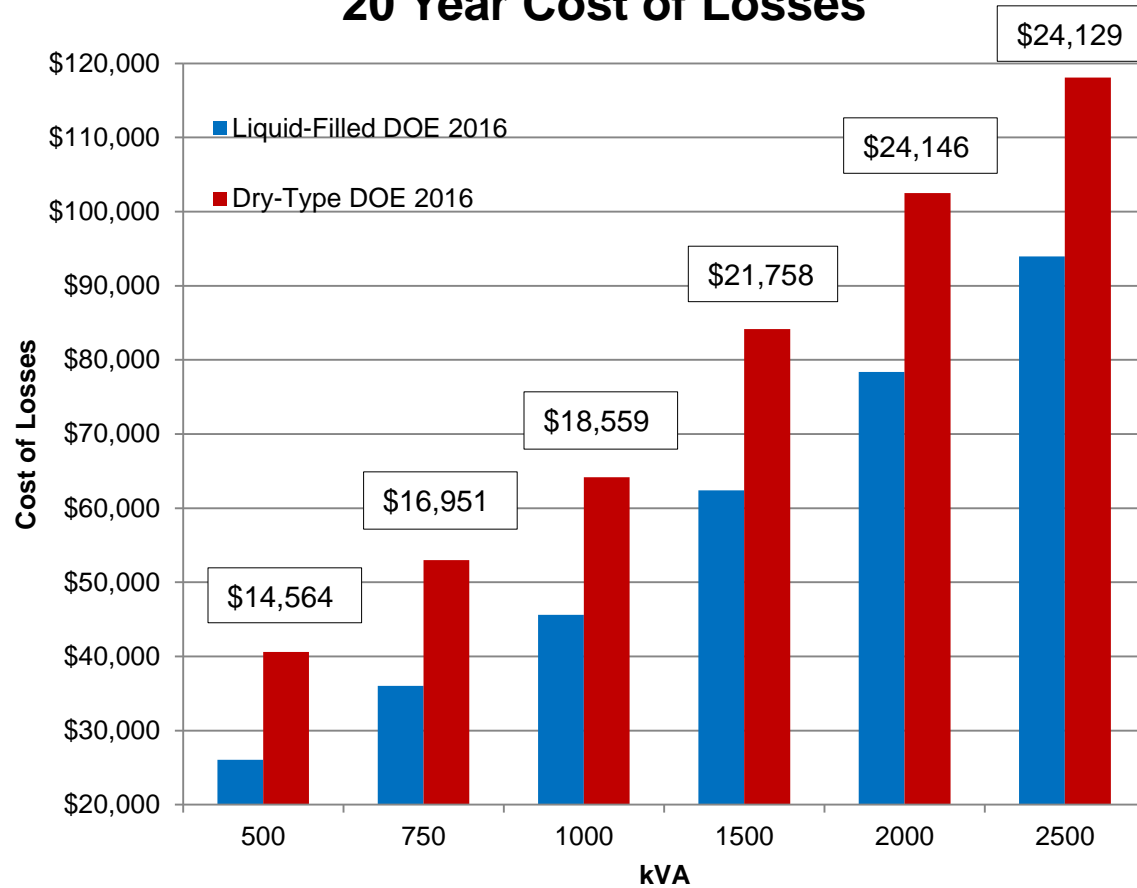

- 15 kV class
- \$0.11/kWh
- 4% interest rate
- 2.3% average inflation
- 50% load

# Total ownership cost – liquid vs. dry

- The Total Ownership Cost (TOC) for liquid-filled transformers is significantly less than dry-type transformers; higher loading represents higher savings

1000 kVA	Liquid	Dry
Unit Price	\$19,000	\$19,000
DOE 2016 Eff.	99.43%	99.20%
\$/kW-hr	\$0.11	\$0.11
Total Watts	2866	4032
TOC @ 50% Load	\$64,617	\$83,176

Liquid vs. Dry Savings over 20 years

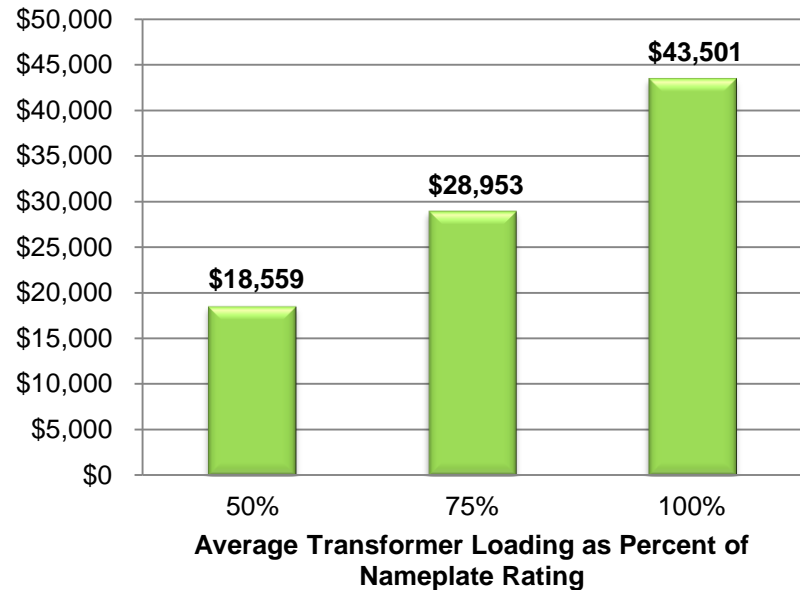

- Dry type TOC does **not** include HVAC costs required for indoor applications; liquid filled savings greater when included in dry-type TOC



# Less-flammable fluid-filled vs. dry

---

- Higher efficiency
- Greater overload capability
- Greater contamination resistance
- Higher BIL's
- Lower temperature operation
- Lower sound levels
- Full diagnostic capabilities
- Fire safety
- Environmental preference
- Longer life
- Smaller footprint
- Dramatic cost savings

# 2014 NEC & Handbook

- 450.23 Less-Flammable Liquid-Insulated Transformers

Transformers insulated with listed less-flammable liquids that have a fire point of not less than 300 C shall be permitted to be installed in accordance with 450.23(A) or 450.23(B).

**(A) Indoor Installations.** Indoor installations shall be permitted in accordance with one of the following:

(1) In Type I or Type II buildings, in areas where all of the following requirements are met:

- a. The transformer is rated 35,000 volts or less.
- b. No combustible materials are stored.
- c. A liquid confinement area is provided.
- d. The installation complies with all restrictions provided for in the listing of the liquid.

(2) With an automatic fire extinguishing system and a liquid confinement area, provided the transformer is rated 35,000 volts or less

(3) In accordance with 450.26 (Oil-Insulated Transformers Installed Indoors)

# Liquid containment

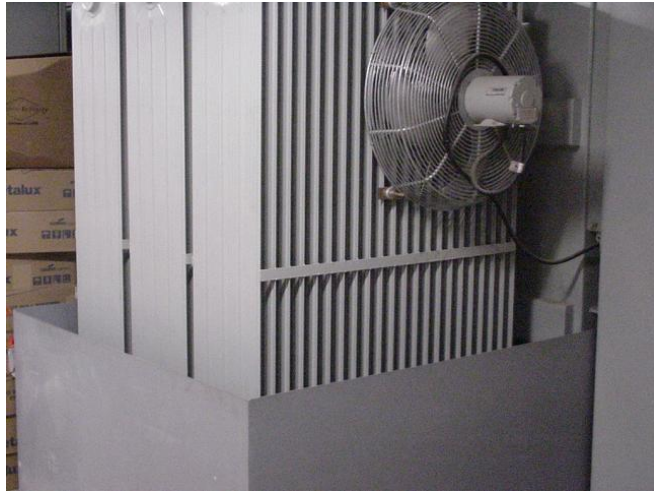

# 2014 NEC & Handbook

---

## **(B) Outdoor Installations.** Less-flammable liquid-filled transformers

shall be permitted to be installed outdoors, attached to, adjacent to, or on the roof of buildings, where installed in accordance with (1) or (2):

(1) For Type I and Type II buildings, the installation shall comply with all restrictions provided for in the listing of the liquid.

*Informational Note: Installations adjacent to combustible material, fire escapes, or door and window openings may require additional safeguards such as those listed in 450.27.*

(2) In accordance with 450.27. (450.27 - Oil-Insulated Transformers Installed Outdoors)

# Building types

---

## Type 1 – Fire-resistive

- Type 1 structures are high-rises, and they're the stoutest of all construction types when exposed to fire. Type 1 structures are constructed of concrete and protected steel and are designed to hold fire for an extended amount of time in order to keep the fire at bay in the room and/or floor of origin.

## Type 2 – Non-combustible

- Type 2 construction is typically found in new buildings and remodels of commercial structures. The walls and roofs are constructed of noncombustible materials. Specifically, walls are usually reinforced masonry or tilt slab, while roofs have metal structural members and decking.

# Fluid listing restrictions

---

- “...the installation shall comply with all restrictions provided for in the listing of the liquid.”
- Two fluid listing options
  - UL classification
  - FM approval
  - Either listing may be utilized to meet NEC 450-23 listing restrictions

# UL Classification

---

- Listed Less flammable fluids
  - 45-10,000 kVA 3-phase transformers
    - Substation
    - Pad-mounted
  - 12 psig internal pressure tank withstand rating
  - Minimum pressure relief device ratings\*
  - Either current-limiting fusing or other over-current protection\*
    - Other over-current protection may include:
      - Externally mounted expulsion fusing
      - Primary breakers
    - Only natural ester based fluid is permitted to use either CL fusing or other over-current protection

\*In accordance with UL classification marking



# UL Classification

## Natural ester based fluid

<b>TRANSFORMER</b>	<b>REQUIRED PROTECTION</b>		<b>REQUIRED PRC</b>
<b>3-Phase Transformer Rating, kVA</b>	<b>Required Current Limiting Fusing (+) Maximum Ft (A<sup>2</sup>s)</b>	<b>OR Required Overcurrent Protection (+) Maximum Ft (A<sup>2</sup>s)</b>	<b>Minimum Required Pressure Relief Capacity, (++) SCFM at 16 psi</b>
45	500,000	700,000	35
75	500,000	800,000	35
112.5	550,000	900,000	35
150	600,000	1,000,000	50
225	650,000	1,200,000	100
300	750,000	1,400,000	100
500	900,000	1,900,000	350
750	1,100,000	2,200,000	350
1,000	1,250,000	3,400,000	350
1,500	1,500,000	4,500,000	700
2,000	1,750,000	6,000,000	700
2,500	2,000,000	7,500,000	5,000
3,000	2,250,000	9,000,000	5,000
3,750	2,500,000	11,000,000	5,000
5,000	3,000,000	14,000,000	5,000
7,500	3,000,000	14,000,000	5,000
10,000	3,000,000	14,000,000	5,000

(+) This is an additional requirement to the overcurrent protection required in accordance with Section 450.3 of the 2002 National Electrical Code.

(++) Opening pressure, 10 psig maximum.

# FM approval

- Approval standard 3990
- FM approved transformer
- Restrictions based on transformer protection very similar to the UL classification except in addition to fusing, pressure relief and tank withstand ratings:
  - Alarm contacts on pressure relief devices for indoor installations > 500 kVA
  - Rapid rise relays > 2500 kVA
  - Temperature, level and pressure-vacuum gages
  - Ground fault CT on neutral
  - Installation limitations, i.e. clearances to walls, etc.



# NEC® compliance

- FM approval requirements

Liquid	FMRC Approved Transformer	Liquid Volume gal/(cu.m)	Horizontal Distance			Vertical Distance ft/(m)
			Fire Resistant ft/(m)	Non-Combustible ft/(m)	Combustible ft/(m)	
Less-Flammable (Approved)	Yes	N/A	3(0.9)	3(0.9)	3(0.9)	5(1.5)
	No	≤10,000	5(1.5)	5(1.5)	25(7.6)	25(7.6)
		>10,000	15(4.6)	15(4.6)	50(15.2)	50(15.2)
Mineral Oil	N/A	<500(1.9)	5(1.5)	15(4.6)	25(7.6)	25(7.6)
		500-5000 (1.9 - 19)	15(4.6)	25(7.6)	50(15.2)	50(15.2)
		>5000(19)	25(7.6)	50(15.2)	100(30.5)	100(30.5)

# FM Approval

<b>COOPER Power Systems</b>		3 $\phi$ TRANSFORMER WAUKESHA, WI U.S.A	
FACTORY MUTUAL APPROVED PER SPEC. 3990			
COOPER CATALOG NUMBER: 004J3A16F75A			
TANK WITHSTAND PRESSURE W/O:		PERM. DISTORTION RUPTURE	7 PSI 15 PSI
PRESSURE RELIEF DEVICE:		MFG: QUALITROL PART NUMBER: 208-001-39	
FUSE TYPE:	EXPULSION, INTERNAL PARTIAL RANGE CLF	FUSE RATING:	100A 23.0KV 165A 23.0KV
FUSE MODEL:	CARTRIDGE PRCLF	PART NUMBER:	4000353C16 354516SM71M
FUSE MFG:	CPS CPS		

1192440AG273-00

1. REPLACEMENT FUSES MUST BE EXACT DUPLICATES OF THOSE INITIALLY PROVIDED.
2. SECONDARY CONTAINMENT EQUAL TO THE LIQUID VOLUME OF THE TRANSFORMER IS REQUIRED FOR ALL INDOOR INSTALLATIONS. SECONDARY CONTAINMENT FOR TRANSFORMERS CONTAINING 660 GAL. OR MORE IS REQUIRED FOR OUTDOOR INSTALLATIONS.
3. INDOOR INSTALLATION REQUIREMENTS:
  - A) FOR TYPE 1 AND TYPE 2 BUILDINGS, THE TRANSFORMER MUST BE LOCATED AT LEAST 3 FT. (0.9M) FROM BUILDING WALL.
  - B) FOR COMBUSTIBLE BUILDINGS, THE TRANSFORMER MUST BE LOCATED AT LEAST 3 FT. (0.9M) FROM BUILDING WALLS AND PROTECTED BY AN AUTOMATIC FIRE SUPPRESSION SYSTEM OR MUST BE INSTALLED IN A 3 HOUR FIRE RATED VAULT.
4. OUTDOOR SITE REQUIREMENTS:  
THE TRANSFORMER MUST BE LOCATED AT LEAST 3 FT. (0.9M) FROM BUILDING WALLS AND 5 FT. (1.5M) FROM DOORS, FIRE ESCAPES AND WINDOWS.
5. SECONDARY GROUND FAULT PROTECTION, OR EQUIVALENT, MUST BE INSTALLED UNLESS SPECIFICALLY PROHIBITED BY THE AUTHORITY HAVING JURISDICTION.



# Less-flammable fluid-filled vs. dry

---

- Higher efficiency
- Greater overload capability
- Greater contamination resistance
- Higher BIL's
- Lower temperature operation
- Lower sound levels
- Full diagnostic capabilities
- Fire safety
- Environmental preference
- Longer life
- Smaller footprint
- Dramatic cost savings

# Pad-mounted substations

## 3-phase pad-mounted transformer scope

- kVA range
  - 45-12,000
  - ONAN / KNAN
- Primary voltage
  - 2400 to 46,000 volts
  - Up to 250 kV BIL
- Secondary voltage
  - 120 to 15,000 volts
  - 125 kV BIL



# Pad-mounted components

Pad-mounted regulators



Pad-mounted reclosers

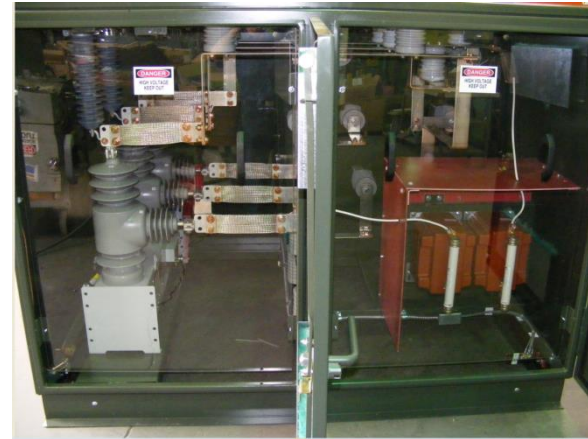

Pad-mounted switchgear



Pad-mounted capacitors





# Pad-mounted substations



# Side by side comparison



Open type substation and 1-phase regulators



Pad-mounted substation with 3-1 pad-mounted regulator & bypass switch



# Modular integrated transportable substation (MITS)



# MITTS



# MIT S



# MIT S

- Configured for supplying electrical loads for sites that extract ground water embedded with natural gas
- designed to be relocated to a new site after its service is complete
- Viewing loads and status of equipment in harsh, remote environments

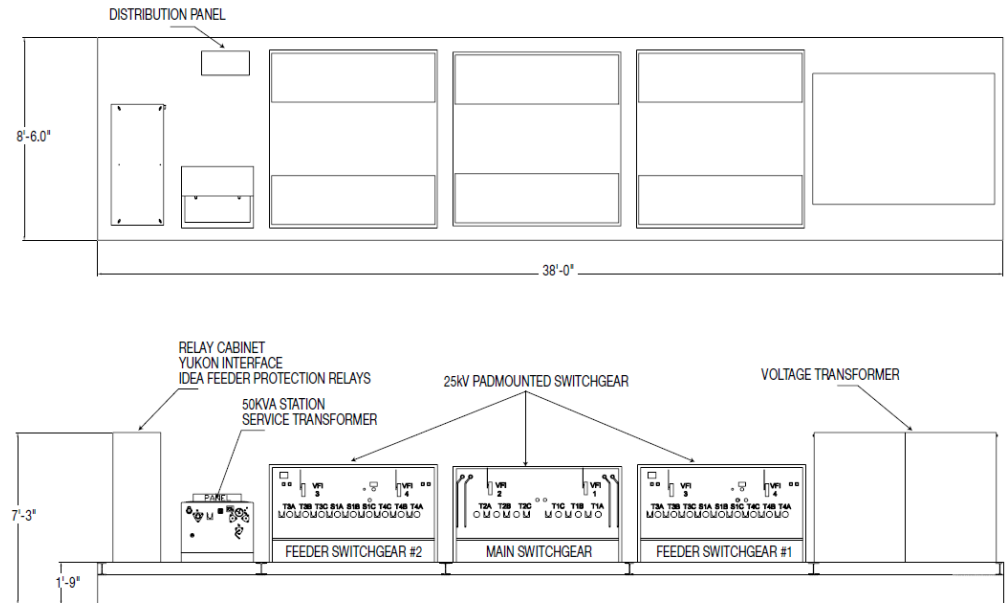

# MIT S

- Furnished for the U.S. Government
- Skid provides quick and reliable portable power for emergency applications
- Step up voltage supplied by generators from 3.6kV to 11kV.
- Quick to install and commission

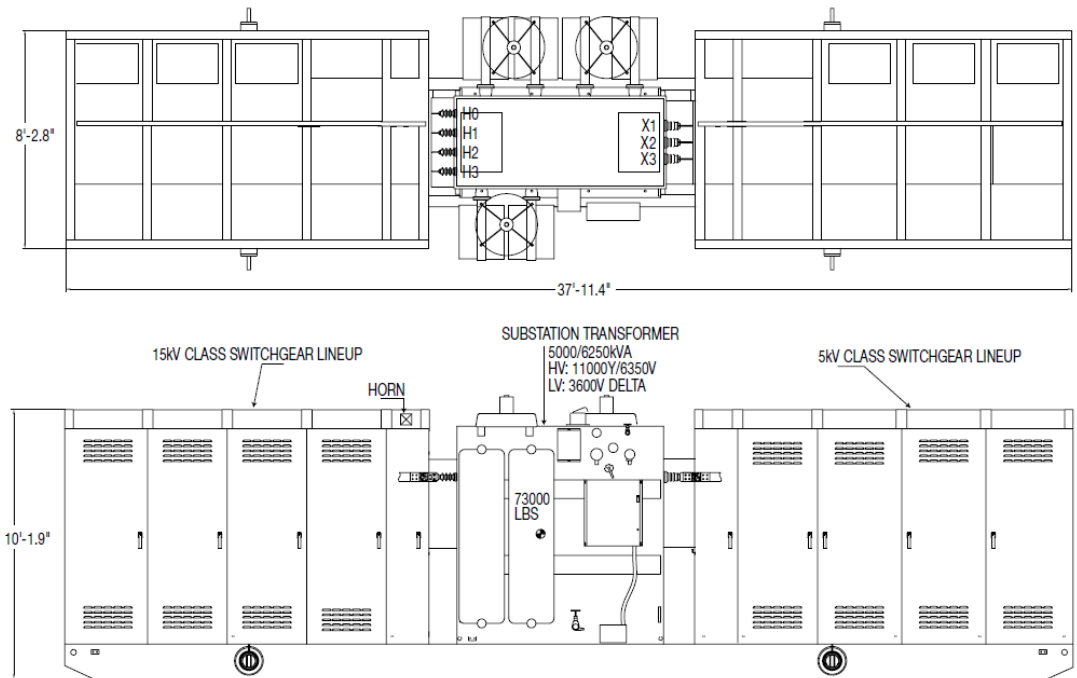

# MIT S

- Substation was needed to serve a remote industrial load
- 2 separate skids joined together at job site
- Surface grading to level the area would have been required for a concrete foundation. Instead of this and to elevate the structure from ground level, steel pillars were installed at weight-bearing points under the entire MITS assembly.

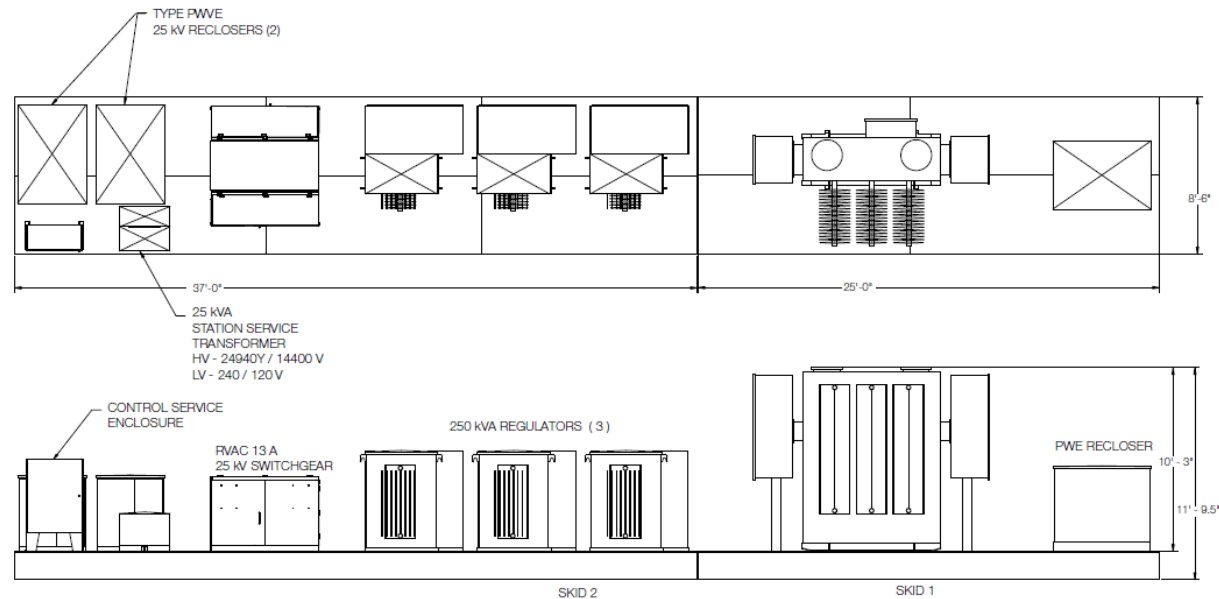



# Reality challenge ... simple enough...



# Modular design





# Triplex design



# Triplex Transformer



**EATON**

*Powering Business Worldwide*